

OPERATION MANUAL



RAMMAX MODELS RX1575 RX157533 TRENCH ROLLER (YANMAR 3TNV76 DIESEL ENGINE)

Revision #0 (04/28/15)

To find the latest revision of this
publication, visit our website at:
www.multiquip.com



THIS MANUAL MUST ACCOMPANY THE EQUIPMENT AT ALL TIMES.

RX1575 Trench Roller

Declaration Of Conformity (CE).....	3
General.....	4-7
Product Description	8-12
Safety Information	13-20
Structure And Function.....	21-23
Operating And Display Elements.....	24-31
Commissioning.....	32
Operation	33-38
Options	39
Maintenance	40-69
Repair	70-82
Storage	83
Transport	84-87
Disposal.....	88-89
Appendix.....	90-94

NOTICE

Specifications are subject to change without notice.

DECLARATION OF CONFORMITY (CE)



Declaration of Conformity

This is to certify that the machine | group of machines indicated below conform(s) to the relevant basic safety and health requirements of the relevant EC directives in terms of their conception and design and in the form marketed by us.

This declaration shall cease to be valid in the event of any change made to the machine/group of machines after handover to the trader/user if such changes are not agreed with us.

Name of machine or group of machines: Trench rollers
Model | Type: Rammax 1575
Mode of functioning: Ground compaction
Serial number: See identification plate
Relevant EC directives:

- Machinery Directive 2006/42/EC
- Directive on Electromagnetic Compatibility 2004/108/EC
- Noise Directive 2000/14/EC

Applicable harmonized standards: EN 500-1, EN 500-4,
Issuing testing office for noise tests: TÜV Austria
Testing office number: 0408
Machine type as per appendix I from 2000/14/EC: No.: 8
Conformity evaluation as per 2000/14/EC: According to appendix VI
Noise emissions: Recorded sound power level: 100dB(A)
Guaranteed sound power level: 103dB(A)
Manufacturer: Ammann Schweiz AG
Address: Eisenbahnstrasse 25
CH-4901 Langenthal

Signatures:

H. Queder
Plant manager

Ch. Anliker
Technology Manager

Name:

Mode of functioning:

Authorized representative:

Place, Date:

The technical documents are stored in the care of the above-mentioned persons
Langenthal, December 2012

1.1 About this manual

This manual is part of the customer documentation for the Rammax 1575 trench roller. It is customer documentation of the Ammann Schweiz AG and its representatives in other countries.

1.1.1 *Target audience*

The target audience for this manual is the owner/operator of the Rammax 1575 trench roller along with his employees who have been authorized for repair, operation and maintenance by the owner/operator.

1.1.2 *Purpose*

The purpose of this manual is to ensure the optimal use and safe application of the roller for the following processes.

- Commissioning
- Operation
- Maintenance
- Repair

1.1.3 *Overview of customer documentation*



Please check that the delivery is complete and inform us within 14 days after purchase if the delivery is not complete. Please always indicate the serial number.

The customer documentation for the trench roller and its components includes, among others, the following customer documents.

- Roller manual
- Spare parts catalog for roller
- Yanmar engine manual in English
- Yanmar engine manufacturer's declaration

Tab. 1-1 Documentation for the Rammax 1575

Language	Manual
German	1230045
English	1230047
French	1230046

1.1.4 *Validity of the manual*

This manual is valid for the following roller:
Rammax 1575

An assortment of optional equipment is available for the roller, which we can install as you wish. For this reason, some of the figures or descriptions in this manual could deviate from your roller.

1.1.5 Storage of the manual

Ammann Schweiz AG delivers every trench roller with this manual. The manual is a permanent component of the roller. Store it so that it is always available for viewing by the users.

Ensure that the manual is complete and legible. If the manual should become lost, damaged or illegible, replace it promptly.

The obligation to properly store the manual for the roller covers the roller's entire service life. If you loan the roller, ensure that the manual is taken along on board the roller. If the roller is sold, hand the manual over to the new owner.

1.1.6 Technical changes

In the interest of technical developments, Ammann Schweiz AG reserves the right to make changes to this customer document at any time without separate notice.

1.1.7 Copyrights



The publisher of this EC compliant customer document is Ammann Schweiz AG.

We reserve all rights for this document and the roller described therein. Reproduction, disclosure to third parties or utilization of its content is forbidden without our express permission. © 2011 Ammann Schweiz AG

1.1.8 Spare parts

In this manual, we describe selected maintenance work. We refer you to your authorized dealer for the remaining maintenance work in accordance with the maintenance plan.

When performing scheduled and unscheduled repairs, you may need to replace components of the roller.

Only use spare parts which meet the requirements specified by the Amman Schweiz AG. These requirement are fulfilled if only original Ammann spare parts are used.

For the ordering of spare parts, we provide you with a spare parts catalog.

1.2 Structure of the manual

The following explanations are designed to familiarize you with the roller and to provide support for handling and maintenance.

It is essential that you read chapter 3 *Safety information* carefully before commissioning and carrying out maintenance work.

Observing the "safety instructions" in particular increases the reliability of the roller in operation and its service life. This reduces repair costs and down time.

1.2.1 Orientation on the roller

When describing the components of the roller, we inform you of their position on the roller. We adhere to the orientation below when doing so.

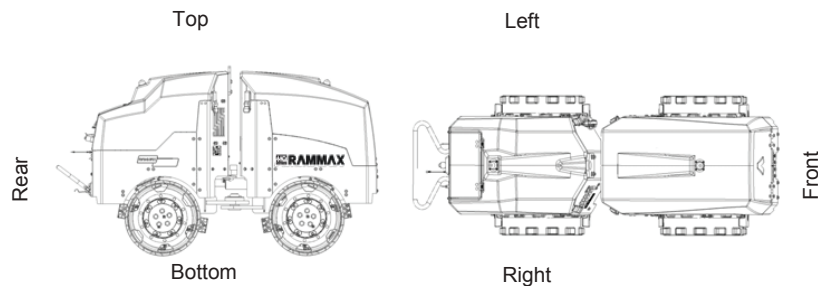

Fig. 1-1 Rammax 1575 orientation

We view the roller from the position of the driver standing behind the roller looking in the direction of travel.

1.2.2 Warnings

Please observe the meaning of the following warnings:



- **DANGER** represents an **immediate hazard** leading to **severe bodily injury** or **death**.



- **WARNING** represents a **possibly hazardous situation** which could lead to **severe bodily injury** or to **death**.

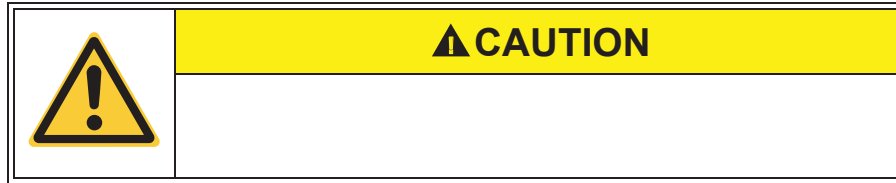

- **CAUTION** represents a **possibly hazardous situation** which could lead to **slight bodily injury**.
- Caution also represents a hazard of **environmental pollution** causing local or global environmental damage.

NOTE

The battery poles and terminals must be clean. If they are coated with a (whitish or greenish) sulfur crust they must be cleaned.

NOTE

Risk of cable fire or short circuit

- **NOTE** represents first of all: damage which could be caused to the roller or parts of it.
- **NOTE** represents secondly: Application tips and other particularly useful information.
- **NOTE** is **not** a signal word for a hazardous or damaging situation.

2.1 Identification of the roller

2.1.1 Machine types

The data given below serve to identify the models. The machine models differ only in terms of weight and the width of the roller drum.



Tab. 2-1 Rammax 1575

Model	Roller Drum Width	Weight
Rammax 1575 with 24" drums with drum rings	24 in (640 mm) 33 in (850 mm)	3,087 lbs (1400 kg) 3,197 lbs (1450 kg)
Rammax 157533	33 in (850 mm)	3,197 lbs (1450 kg)

2.2 Product data

2.2.1 Dimensions

Fig. 2-1 1575 dimensions

2.2.2 Specifications

Tab. 2-2 Rammax 1575 performance data

Rammax 1575		
Roller drum width in (mm)	24 (640)	33 (850)
Service weight according to CECE lbs (kg)	3,087 (1400)	3,197 (1450)
Static linear load lbs/in (kg/cm)	10.1 (11.6)	7.7 (8.9)
Inside turning radius in (mm)	61 (1541)	57 (1436)
Outside Turning Radius-in (mm)	86.25 (2,191)	90 (2,286)

PRODUCT DESCRIPTION

Low/ High amplitude in (mm)	.024 (0.6)/.043 (1.1)	
Gradient in % with/without vibration	40/50	
Drive	YANMAR 3TNV76/EPA 4	
Performance according to ISO 3046	15.0kW/20.4HP	
Operating speed	2400 1/min	
Low Travel Speed ft/min (m/min)	82 (25)	
High Travel Speed ft/min (m/min)	148 (45)	
Steering angle/pivoting	+/-30° / +/-7°	
Vibration frequency	vpm (Hz)	2,460 (41)

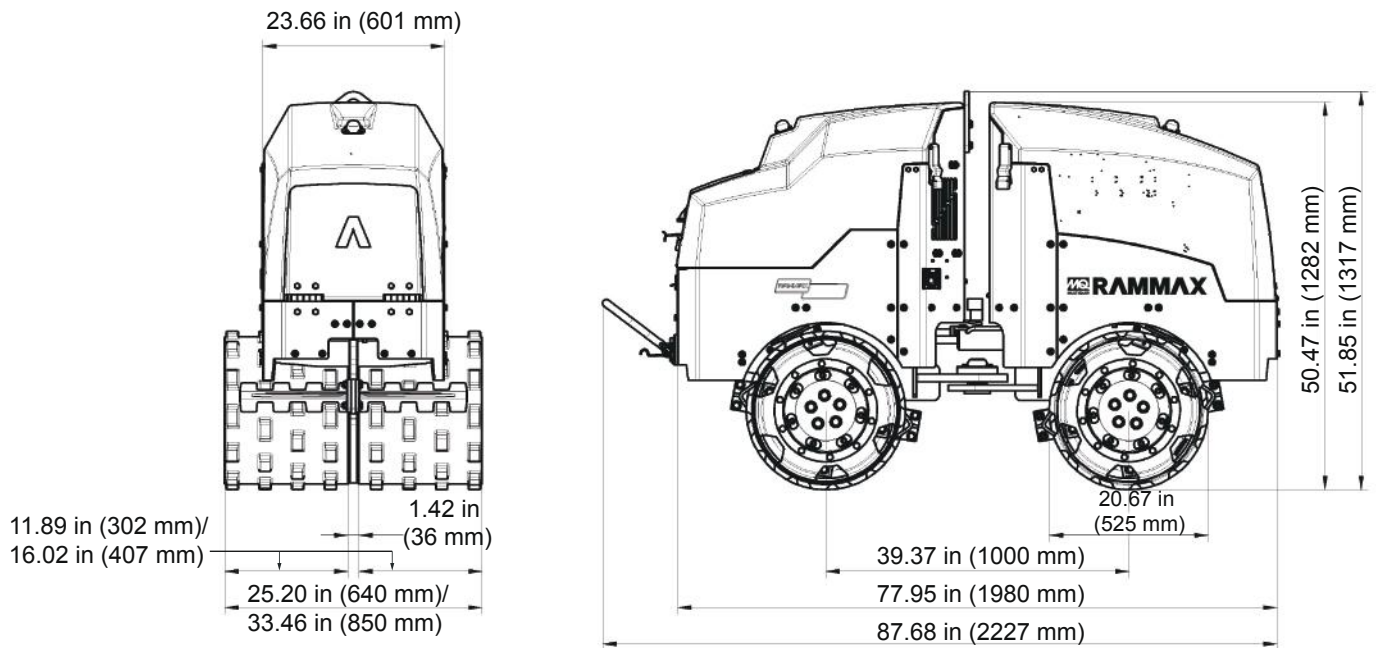

Filling capacities Tab. 2-3 Rammax 1575 filling capacities

Container	Contents
Hydraulic Oil Tank gal (liter)	4.2 (16)
Diesel Fuel Tank gal (liter)	7.4 (28)

2.3 Roller designation

2.3.1 Identification plate

An identification plate is affixed to the roller for identification. The identification plate is attached to the rear part of the chassis below the steering column.

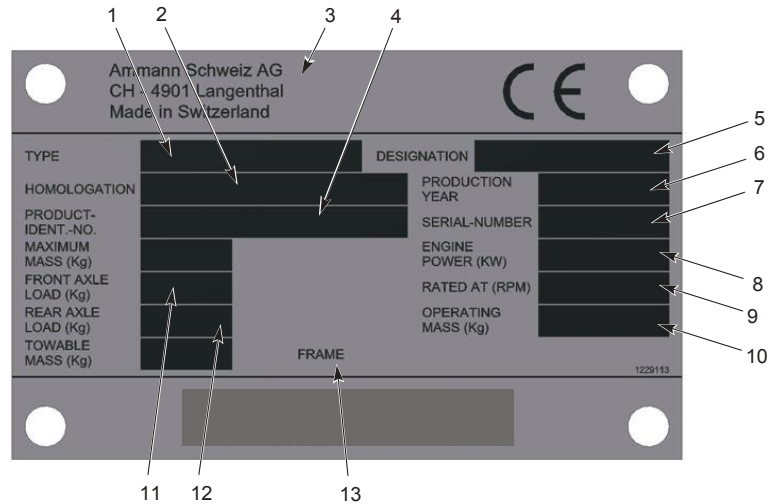

Fig. 2-2 Data on the identification plate

- 1 Roller designation
- 2 Homologation number
- 3 Name and address of the manufacturer
- 4 Vehicle Identification Number (VIN)
- 5 Roller model
- 6 Year of manufacture
- 7 Serial number
- 8 Fuel engine output at
- 9 Speed of fuel motor (rpm)
- 10 CECE total weight
- 11 Axle load, front
- 12 Axle load, rear
- 13 Number stamped in chassis

NOTE

When ordering spare parts you must indicate the serial number (S/N) of the roller.

2.4 Intended use

2.4.1 *Intended purpose of the Rammax 1575*

The Rammax 1575 trench roller is a roller specially designed for trench compacting. The unlimited side clearance of the roller drums allows compacting in very narrow, tight trenches right up to the trench walls. The wet, clayey soils found in sewer construction, pipeline construction, road foundations and construction backfilling, etc., are the areas of application for this modern trench roller. The infrared remote control also makes it possible to drive underneath trench shoring in trenches. In hazardous construction site applications, it is possible for the operator to control the machine from a safe distance with no personal risk.

Normal modes of operation Use the Rammax 1575 roller exclusively for driving on and compacting:

- Unbonded layers (earth, gravel, crushed stone).

Special operating modes

- Transport of the roller from A to B (crane and low loader).
- Cleaning the roller.
- Maintenance of roller according to maintenance plan or in the event of defects.
- Rectification of machine faults by trained personnel based on error messages.
- Towing the roller.
- Proper disposal by the operator in accordance with national regulations.

2.4.2 *Requirements for the roller driver*

Only trained, suitable and reliable specialists may operate the rollers.

2.4.3 *Application limits*

Tab. 2-4 Limits for application in consideration of environmental conditions

	Operation	Storage
Temperature limit	-10°C to +48°C	-25°C to +48°C
Humidity	All-year operation/outdoor storage	
Terrain	Graded	Graded
Upslope	40% with -/50% without vibration	max. 15%
Downslope	40% with -/50% without vibration	max. 15%

2.5 Inappropriate use

Inappropriate use includes any use not listed under intended use. Note the following in particular:

- The roller is not a playground.
- The roller must not be used as a traction vehicle.
- The roller is not a passenger transporter.
- In the case of movements greater than 3km, the roller must be loaded on a transporter.
- The roller is not a rock crusher, breaking chisel or similar.

2.5.1 *Disclaimer*

Ammann Schweiz AG accepts no liability for the continued reliable functioning of the roller if it is not used appropriately.

Unauthorized conversions and changes to the roller are prohibited for safety reasons and void any and every Ammann guarantee as well as, possibly, the CE directive.

Replaced spare or wear parts must meet the technical requirements specified by Ammann. These requirements are fulfilled if only original Ammann spare parts are used.

The instructions given in the various sections must be adhered to. The safety instructions must be observed at all times. Failure to adhere to working instructions, their correct order, safety instructions or safety labeling requirements causes liability claims to become void.

3.1 General working safety

- The roller may only be used for driving on and compacting loose top layers (gravel, earth). Other uses are prohibited.
- Rollers may only be operated with all safety devices operating. Manipulation or disregard of safety devices and regulations invalidates the CE conformity.
- Before starting every shift, check the effectiveness of the operation and safety devices and that the protection devices are in place.
- Check the steering and brakes when you start work. If defects are apparent, roller operation is not permitted.
- If you identify any defects on the safety system or defects that impair safe operation of the equipment, inform your supervisor immediately. The roller may no longer be operated.
- If you identify any defects which endanger safe operation, cease operation immediately.
- Only perform work on and clean the roller if it is stationary and secured from rolling away.
- Switch off the engine when filling the fuel tank. Do not fill up fuel in enclosed spaces. No open flames.
- Do not vibrate on slopes or inclines where there is a hazard of slipping or overturning.
- Do not drive on slopes that are steeper than the maximum climbing capacity of the equipment. Always drive the roller carefully perpendicular to the slope dip.
- Do not vibrate inside buildings and on unstable ground.
- The driving and working field of view must not be obstructed in any way.
- Switch off the engine before leaving the roller. Secure the roller against unauthorized start-up and rolling away.
- Take suitable visible measures to secure parked rollers that pose an obstruction.
- Never work under the influence of drugs, alcohol or medicines that impair consciousness.
- Only operate the roller in good general light conditions and good workspace illumination.
- The workplace of the operator is located at a safe distance of at least 2m.

3.2 Roller operation

	▲ DANGER
	Rollover hazard when driving the roller! <ul style="list-style-type: none">• Only start the roller using the handheld transmitter.• Personnel may not stand in front of or behind the roller while it is in operation.• Persons necessary for operations at the sides of the equipment must remain at a safe distance of at least 2 m.

3.2.1

Shear points

- When closing the hood ensure that no objects are situated between the hood and the chassis.
- Take care that nothing is jammed in the joint plates when rotating the roller drums.
- Do not put hands between the roller drum and support during operation.

⚠ DANGER	
	<p>Danger to life through tipping or slipping of the roller! The edges of filled areas may give way!</p> <ul style="list-style-type: none">• Only travel directly up or down slopes.• Do not drive across slopes.• Keep your distance to embankments and edges!• Do not drive at an angle into or out of the trench.• Park the roller on slopes only in such a way that it cannot overturn.• Use the roller on slopes only in such a way that it cannot overturn.• The roller drums have very poor adhesion on snow and ice. Driving or working on a slope in snow or ice is prohibited.• Damp and loose surfaces reduce the traction of the machine on upward and downward grades considerably. Adapt the speed of the machine to the terrain when driving on grades.• The nature of the ground and weather conditions can negatively affect the climbing ability of the machine. Never drive on slopes that are steeper than the maximum climbing ability of the machine.

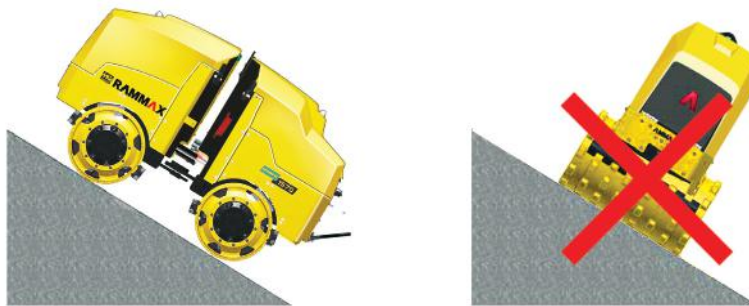
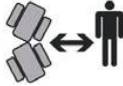



Fig. 3-1 Tipping hazard

Construction site conditions can have a negative effect on stability and the tipping angle.

	⚠ DANGER
	Crushing hazard in the area of the articulated joint <ul style="list-style-type: none">• During operation, there is always a crushing hazard in the area of the articulated joint. Therefore, it is not permitted for persons to be in this area during operation. In general, a safety distance of at least 2 meters to the machine must be maintained during operation.

	⚠ DANGER
	Crushing of toes through careless handling of the roller! <ul style="list-style-type: none">• Wear safety shoes when working with the roller in order to help avoid crushed toes.

	⚠ DANGER
	Danger of accident through improper operation of the roller! <ul style="list-style-type: none">• Read the operating instructions before operating the roller.• Adhere to the safety regulations at all costs.• In case of lack of clarity, contact your authorized dealer.

3.3

Noise levels



	⚠ WARNING
	Hearing damage due to continuous noise level! <p>Depending on the use of equipment it is possible that the allowed noise level of 85dB (A) will be exceeded.</p> <ul style="list-style-type: none">• Wear ear protectors in accordance with national accident prevention regulations when working at higher noise levels.

The following noise level measurements were carried out by an accredited testing and monitoring body in accordance with machine directive 2000/14/EEC of the European parliament and council.

Inspecting and monitoring organization: TÜV Österreich (Austrian technical inspectorate) Testing body no. 0408

Tab. 3-1 Sound power level

Model	Value
Measured sound power level	100dB (A)

NOTE

The obligation to wear ear protection is standardized nationally. In Switzerland and Germany, this is as of a measured level of 85dB (A) (sound pressure).



3.4 Safety markings on the machine

- Observe and adhere to the rules.
- Keep the safety stickers and signs complete and legible.
- Replace any damaged or illegible stickers and signs immediately.
- You can order new stickers from Ammann Schweiz AG.



From the moment the signs are no longer recognizable and understandable at first glance, the machine must be shut down until new signs are installed.

3.4.1 Warning stickers



Tab. 3-2 Warning stickers on board

Warning stickers	Meaning
	<p>Location on roller: Air intake opening/Inside of cowling</p> <p>Danger: Damage to electrical controls!</p> <p>Explanation: Never spray a water jet into electrical or electronic components. Never spray into the engine combustion air intake.</p>
	<p>Location on roller: Outer cowling cover.</p> <p>Danger: Danger of injury due to incompetent operation:</p> <p>Explanation: Read the operating instructions before operating the roller. Adhere to the safety regulations at all costs. Contact your authorized dealer if anything is unclear.</p>

SAFETY INFORMATION

Warning stickers	Meaning
	<p>Location on roller: Between the front and rear parts of the roller.</p> <p>Danger: Crushing hazard!</p> <p>Explanation: Only stand in this area when necessary and only with extreme caution!</p>
	<p>Location on roller: In the middle of the front and back.</p> <p>Danger: Rollover hazard</p> <p>Explanation: Only stand in this area when necessary and only with extreme caution!</p>
	<p>Location on roller: Radiator, both sides.</p> <p>Danger: Warnings for cooling water radiator</p> <p>Explanation: Do not put hands in the radiator fan when the machine is running.</p>



SAFETY INFORMATION

Warning stickers	Meaning
	<p>Location on roller: Inner cowling cover. Designation: If the roller has overturned, do not start the machine. Explanation: Avoid oil shock.</p>
	<p>Location on roller: Outer cowling cover. Requirement: Wear ear protectors! Explanation: Wear ear protectors in accordance with national accident prevention regulations when working at higher noise levels.</p>



3.4.2

Notice stickers

Tab. 3-3 Notice stickers on board

Notice stickers	Meaning
	<p>Location on roller: Chassis rear Designation: Guaranteed sound power level. Explanation: Indicates the overall noise level produced by the roller.</p>
	<p>Location on roller: On the hydraulic oil tank Designation: Hydraulic oil Explanation: Please only use hydraulic oil indicated</p>

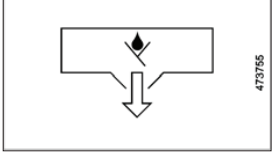
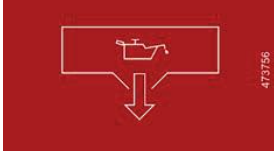
SAFETY INFORMATION

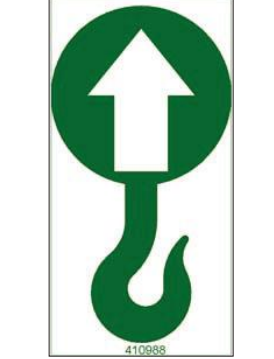
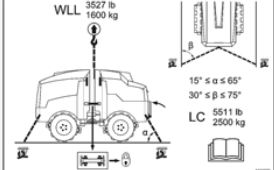
Notice stickers	Meaning
	<p>Location on roller: Chassis rear. Designation: Hydraulic oil drain. Explanation: Drain hole for the hydraulic oil</p>
	<p>Location on roller: Chassis, front right. Designation: Motor oil drain. Explanation: Drain hole for the motor oil</p>
	<p>Location on roller: Chassis rear. Designation: Fuel. Explanation: Filler neck for diesel fuel.</p>
	<p>Location on roller: On the middle of the front and rear chassis. Designation: Tie-down point. Explanation: Points on the roller at which lashing means for securing the roller on the transport vehicle can be attached.</p>
	<p>Location on roller: Roll bar, rear. Designation: Suspension hooks. Explanation: Points on the roller at which hoisting tackle for lifting the roller can be attached.</p>
	<p>Location on roller: Rear chassis, front upper left. Designation: Lifting and tie-down points. Explanation: Illustrates how the machine is to be loaded and transported.</p>

SAFETY INFORMATION

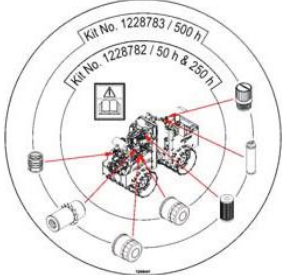
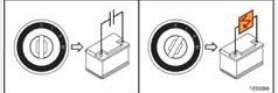
Notice stickers	Meaning
	<p>Location on roller: Rear chassis, front upper left. Designation: Spare parts information Explanation: Information about the filters of the machine.</p>
<div style="border: 1px solid black; padding: 5px;"> <p style="text-align: center;">Achtung</p> <p>Beim Fahren mit Fernsteuerung sowie beim Parken der Maschine muss der Deckel geschlossen sein.</p> <p style="text-align: center;">Attention</p> <p>During driving with remote control and during parking the machine the cover must be closed.</p> <p style="text-align: center;">Attention</p> <p>Pendant conduire avec commande à distance et pendant parquer la machine, le couvercle doit être fermé.</p> <p style="text-align: right; font-size: small;">3-39672</p> </div>	<p>Location on roller: Inner cowling cover. Designation: Close the cover. Explanation: Attention: When driving using remote control and when parking the machine, the cover must be closed.</p>
	<p>Location on roller: Inner cowling cover. Designation: Ignition Explanation: Attention: Current is present when the ignition is on.</p>

3.5

Radiation compliance

This machine complies with the emission requirements for radio interference due to radiation, European Norm EN 13309, for construction machinery.

4.1 Component overview

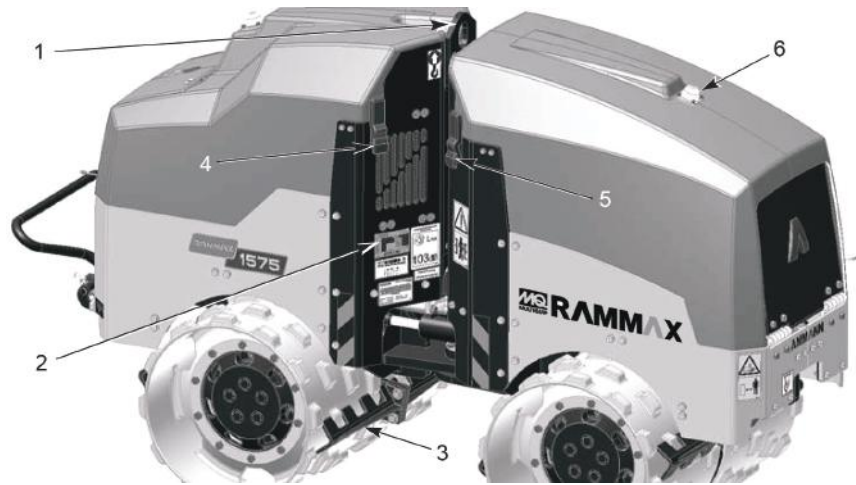

Fig. 4-1 View from the right

- 1 1-point lifting eye
- 2 Identification plate
- 3 Roller drum scraper
- 4 Rear hood latch (cowling)
- 5 Front hood latch (engine hood)
- 6 Front infrared sensor

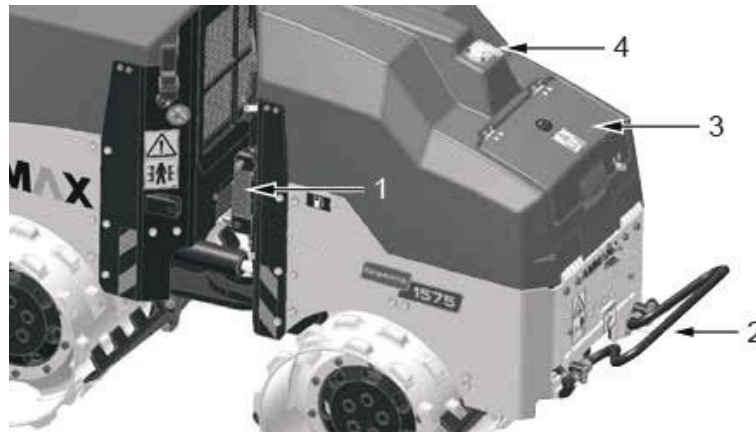

Fig. 4-2 View from left

- 1 Articulated joint protection
- 2 Shutdown bar (optional)
- 3 Cockpit cover
- 4 Rear infrared sensor

STRUCTURE AND FUNCTION

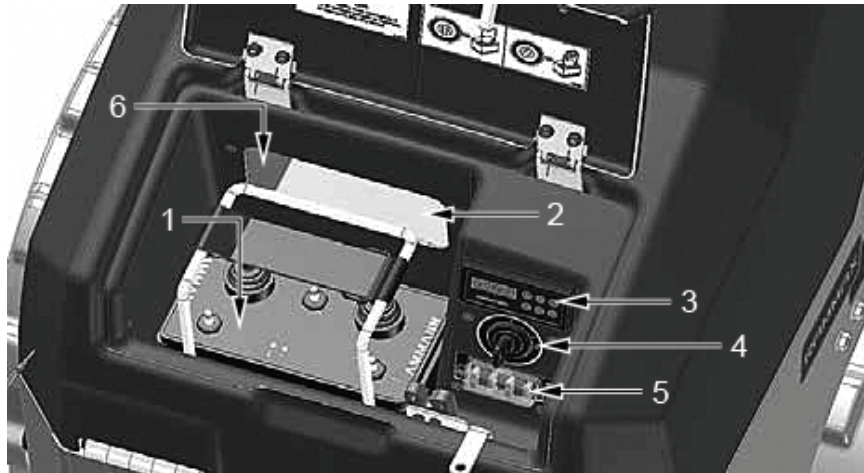

Fig. 4-3 Cockpit overview

- 1 Infrared transmitter
- 2 Storage area for spiral cable
- 3 Display unit
- 4 Ignition switch
- 5 Fuses
- 6 Connector for spiral cable to infrared sensor (back area)

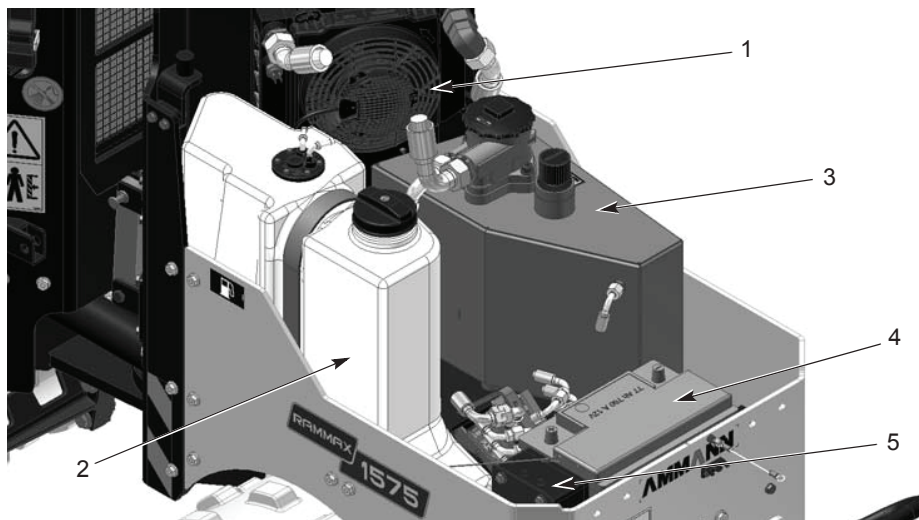

Fig. 4-4 Overview of interior of rear chassis

- 1 Oil cooler
- 2 Fuel tank
- 3 Hydraulic tank
- 4 Battery
- 5 Controller (machine controller)

STRUCTURE AND FUNCTION

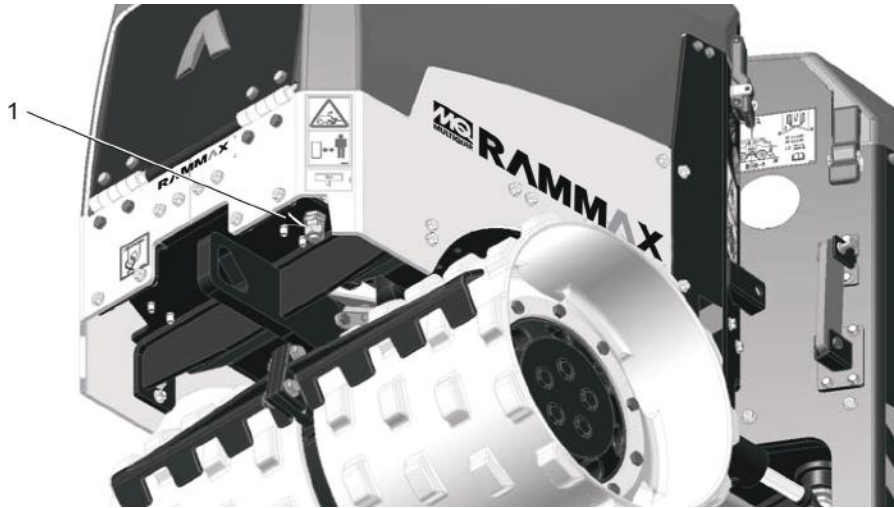

Fig. 4-5 Front bottom view

- 1 Engine oil drain plug

OPERATING AND DISPLAY ELEMENTS

5.1 Display unit

5.1.1 Control lamps

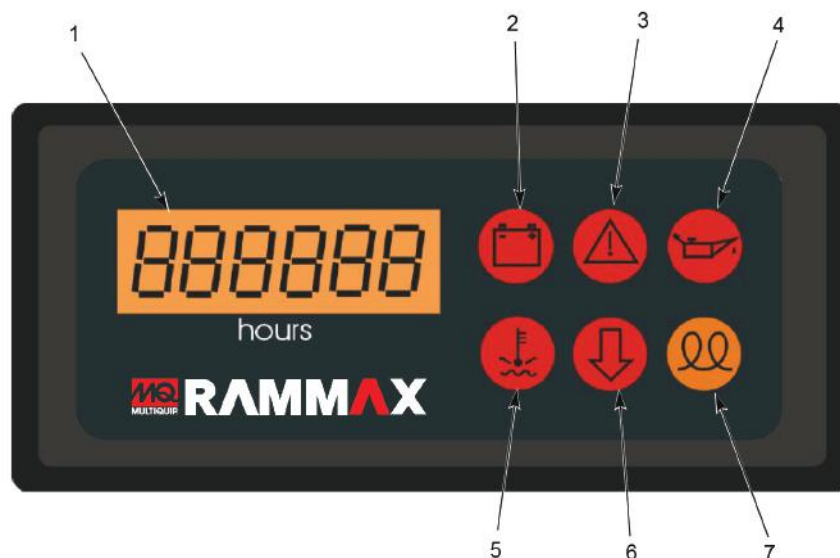

- 1 Display/operating hours counter
- 2 Control lamp for battery charge level (charge control)
- 3 Error control lamp
- 4 Control lamp for engine oil pressure
- 5 Control lamp for cooling water temperature
- 6 Control lamp for shutdown bar
- 7 Control lamp for pre-heating

The control lamps for engine oil pressure and charging light up when the ignition is switched on. They extinguish once the engine is running.

5.1.2 Control lamp functions

Error



The **Error control lamp** lights as soon as the controller recognizes an error. Error codes are shown on the LED display.

- 1 Check whether the desired function is working. (This also applies when the tilt sensor is triggered.)

If the battery charging lamp is still lit after carrying out these checks, call a specialist.

OPERATING AND DISPLAY ELEMENTS

Battery



If the **battery charge level control lamp** lights up during operation or does not go off after starting, carry out the following check immediately.

- 1 Stop the engine.
- 2 Check the engine for defective or loose V-belt.

If the battery charging lamp is still lit after carrying out these checks, call a specialist.

Engine oil pressure



If the **engine oil pressure control lamp** lights up during operation or does not go off after starting, stop the roller and turn off the engine immediately!

- 1 Check the engine for oil loss and correct oil level.
 - 1.1 The oil level in the engine is correct: Call a specialist to remedy the problem.

NOTE

The machine is equipped with an automatic shutdown system. If the oil pressure falls below the limit value, the oil pressure warning lamp lights up. After the warning lamp has been lit for 4 seconds, the machine is shut down.

Coolant temperature



	▲ WARNING
	Danger of scalding! The cooling circuit is pressurized.

NOTE

Danger of engine overheating. Stop immediately!

If the **coolant temperature control lamp** lights up during operation of the machine, switch off the engine **immediately** and top up coolant!

- 1 Allow the engine to cool down.
- 2 Remove the radiator cap.
- 3 In order to avoid scalding, first unscrew the radiator cap one turn and allow the pressure to drop.
- 4 As soon as the pressure has dropped, remove the cap and top up the liquid.
- 5 Check the cooling system for leaks and the radiator/expansion vessel for correct coolant level.
 - 5.1 You are unable to find an error: Call a specialist to remedy the problem.

NOTE

The machine is equipped with an automatic shutdown system. If the cooling water temperature exceeds the limit value, the temperature warning lamp lights up. After the warning lamp has been lit for 4 seconds, the machine is shut down.

OPERATING AND DISPLAY ELEMENTS

Pre-heating



The pre-heating time lasts about 6 s. The **pre-heating indicator lamp** extinguishes when the engine is started.

Shutdown bar (OPTIONAL)



The **shutdown bar indicator lamp** remains lit as long as the shutdown bar is actuated.

- 1 Check whether the shutdown bar has been released.
- 2 Release the shutdown bar.

5.1.3 LED error display on the display unit

Error display

Tab. 5-1 Error display (tilt switch)

Display	Cause	Remedy
Error lights up	The tilt switch has been triggered. The roller is at an angle of more than about 45° or has tipped over.	Set the machine upright.

NOTE

For safety reasons, as soon as the roller tips over, the ignition is also shut off.

The machine controller is equipped with an inclination sensor. It triggers as of an angle of 45°. In this case, the engine shuts itself off automatically. The machine cannot be started as long as the inclination sensor remains triggered.

If the machine has tipped over, it is possible for engine oil to enter the combustion area. If the machine is started after it has been righted, engine damage is possible.

- Set the machine upright. Do not start the engine under any circumstances.
- Inform the service workshop.

Tab. 5-2 Error and shutdown bar display

Display	Cause	Remedy
Error lights up	A switching transistor signals a status error. This means that, for example, a short circuit or a cable break has been detected.	Check the cable for a short circuit or cable break.
Error and shutdown bar light up in unison	The machine controller is waiting for both the inputs "Oil pressure" and "Lima" to be at the rest position.	Check the oil pressure and lima outputs.

NOTE

Bear in mind the priority of the displays: First is the tilt switch, then "Wait" and last, the status error transistor.

OPERATING AND DISPLAY ELEMENTS

Display
Shutdown bar

Tab. 5-3 Shutdown bar display

Display	Cause	Remedy
Shutdown bar lights up	Switch on shutdown bar has triggered.	Move the shutdown bar to its original position.
Shutdown bar is blinking	Close proximity shutdown has been detected.	Move more than 2m away from the roller.
Shutdown bar is flashing	Close proximity has been detected.	If the roller is controlled by means of the cable, the user must be present in the close proximity area (between 2 and 4m)

NOTE

Bear in mind the priority of the displays: First the bar switch, then the close proximity shutdown and last, the close proximity area.

5.2 Infrared transmitter

5.2.1 Design



Fig. 5-1 Infrared transmitter

- 1 Work gear/transport gear
- 2 Forward travel/backward travel
- 3 Large/small amplitude vibration
- 4 Steering angle left/right

OPERATING AND DISPLAY ELEMENTS

- 5 Start/Stop
- 6 LED (error and charging display from IR transmitter)
- 7 Cable

5.2.2 LED error display on the IR transmitter

There are two LEDs on the cover: a green one and a red one.

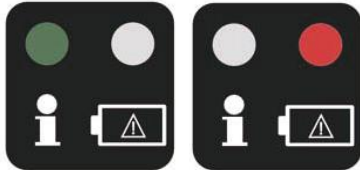

Fig. 5-2 LED error display, green/red

Standard

Tab. 5-4 Standard display

Display	Cause
The green LED is blinking slowly.	The roller is being controlled via the cable.
The green LED is flashing.	The roller is being controlled via infrared.

Battery charge monitoring

The red LED blinks either faster or slower depending on the battery charge level. The lower the charge state, the longer the on-phase of the LED.

Tab. 5-5 Battery charge monitoring display while performing a function

Display	Cause	Remedy
The red LED flashes briefly	The battery is slowly becoming drained	Connect the charging cable for at least 1 h.
The red LED always lights when a control is operated.	When the battery is drained, it is no longer sent.	Connect the charging cable for at least 1 h.
The red LED flashes.	The battery is being charged.	
The red LED is lit.	The battery is fully charged.	

NOTE

It is still possible to control via the cable once the battery is empty.

Battery warnings and errors are only displayed during active control (i.e., when a control element is actuated).

As soon as and as long as the infrared transmitter is attached to the machine controller via the cable and the ignition is turned to I, the red LED must flash or be lighted.

OPERATING AND DISPLAY ELEMENTS

Automatic pairing *Tab. 5-6 Automatic pairing display*

Display	Cause
The green and red LEDs are blinking in unison quickly.	The infrared transmitter is coupled with the machine controller.

NOTE

This procedure normally only takes a maximum of about 3 seconds. If this blinking lasts longer or should even become permanent, there is a problem with pairing:

- A cable break in one of the signal lines
- A short circuit in one of the signal lines

As long as this blinking pattern remains, no control signals will be sent to the machine controller.

Automatic pairing occurs at the moment the cable is unplugged, or, if the cable is plugged in, when the infrared transmitter is switched on.

Special cases

- When the infrared transmitter is switched on, both LEDs are switched on briefly. This feature helps to determine that the LEDs are still functioning.
- As soon as the cable is unplugged from the handheld transmitter or from the roller, the red LED lights up for about 1 second.

5.2.3

Cable connection



Fig. 5-3 Spiral cable connector

- 1 Spiral cable connector/protective cover fastener
- 2 Solar cells/Transmission elements

OPERATING AND DISPLAY ELEMENTS

5.2.4 Handling

Sticker



The infrared transmitter is located in the black lower part of the housing. It contains the following transmission elements:

- The solar cells
- The infrared diodes for data transmission and measuring the safety distance.



- Before startup, clean the transmission elements.
- Before startup, be sure that the solar cells in the lower part of the housing are not covered over.
- Keep the solar cells clean during operation.

⚠ CAUTION	
	<p>Accident hazard due to covered over lower part of the housing!</p> <ul style="list-style-type: none">• Before and during operation with the infrared transmitter, make sure that the entire lower part of the housing remains completely uncovered for the entire time of operation.• In particular, the operator's hand must not cover the lower part of the housing even partially.

Wear the infrared transmitter correctly

- 1 Pay attention to correct positioning.
 - 1.1 The cable connector must face forwards or be oriented according to the sticker on the transmitter. The infrared transmitter may rest on the stomach of the operator.
 - 1.2 Adjust the strap for the correct length to ensure optimal wearing comfort.
- 2 Pay attention to correct operation.
 - 2.1 Only hold the housing by the upper part; see the warning information.

OPERATING AND DISPLAY ELEMENTS

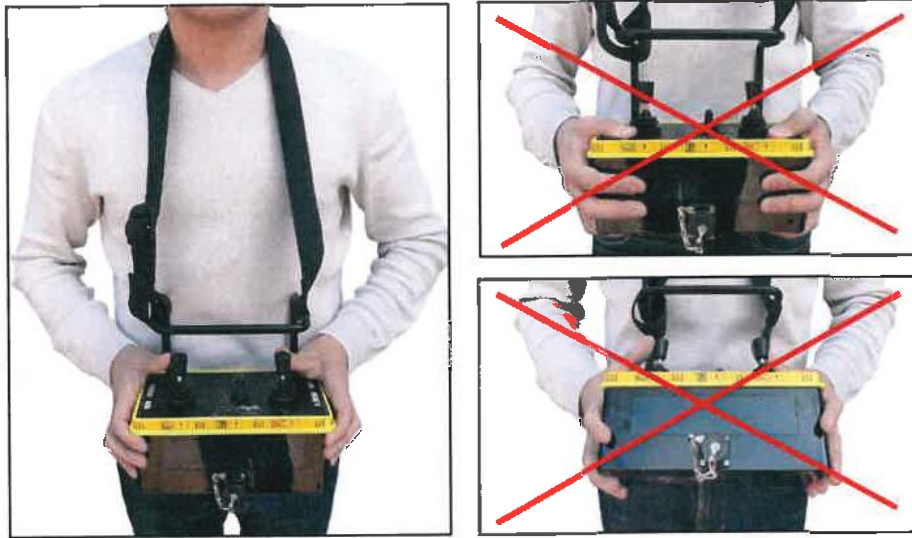

Fig. 5-4 Wear the infrared transmitter correctly

NOTE

Be certain that the desired confirmation can be carried out safely.

6.1 Commissioning

NOTE Familiarize yourself with the manual before commissioning.

6.1.1 *Inspection before commissioning*

In order to begin operating the roller (driving), the following conditions must be fulfilled:

The following must be checked:

- The function of all safety devices
- Whether the transport restraint has been removed
- Whether the shutdown bar has been released
- All screw connections for tightness
- Fuel tank and pipes for leaks
- Machine and engine for damage
- Function of the controls
- Function of the steering
- Hydraulic system for leaks
- IR transmitter battery status (LED must be lit).
- Pair infrared transmitter with the machine controller (see below).
- Electronic ballast interference (an external influence from fluorescent tubes)

NOTE The infrared transmitter does not work and no LEDs are lit.

- **Connect the transmitter to the machine via the spiral cable. The battery will be charged!**

6.1.2 *Automatic pairing of infrared transmitter and machine controller*

In order to operate the machine using the infrared transmitter, they must first perform a mutual address assignment. This is only necessary if a new infrared transmitter must be registered on the machine.

- 1 Connect the cable to the transmitter.
- 2 Turn the ignition key to position I.
- 3 After approx. 3 seconds, the cable can be removed.

The cable is not required for infrared operation.

NOTE Pairing is required in order to operate the machine with a new infrared transmitter. Pairing ensures that only one machine can be operated with one transmitter.

The green LED and the red LED blink during pairing

7.1 Protection against vandalism

Always fold the vandalism protection cover upward before start-up of the roller.

The vandalism protection cover protects the display unit and the infrared sensor from:

- the effects of weathering
- vandalism
- alterations by third parties

If you wish to secure the display unit and the infrared sensor from unauthorized access by third parties, you can install a padlock on the loop provided for this purpose.

Commercially available padlocks can be obtained in any building supplies store.

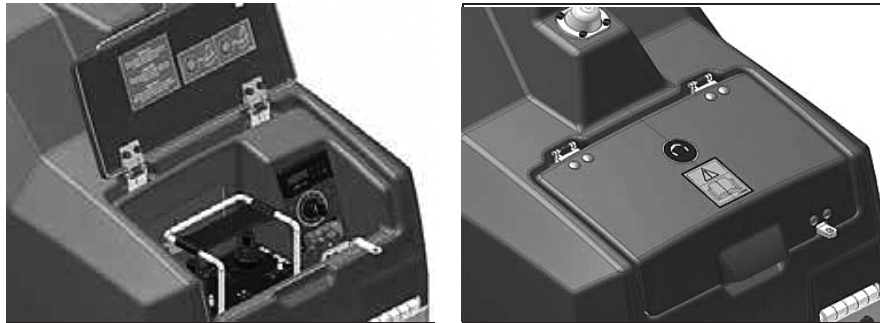

Fig. 7-1 Vandalism protection cover opened/closed

7.2 Start the engine

7.2.1 Starting the engine using the ignition switch



- 0 Off**
All electrical loads are off.
- I Ignition on**
All electrical consumers can be switched on.
- II Pre-heating**
- III Start**

7.2.2 Starting the engine using the infrared transmitter

- 1 Turn the ignition key clockwise to position I.
- 2 Hold the switch on the infrared sensor in the start position.
 - 2.1 Preglow for a max. of 6sec.
- 3 Release the switch.



Fig. 7-2 Start the engine/Infrared sensor

NOTE The control lamps for engine oil pressure and charging light up when the ignition is switched on. They extinguish once the engine is running.

Pre-heating If the outside temperature is below 0°C:



- 1 Turn the ignition key to position II.
 - 1.1 Hold it in this position for max. 6 sec.
- 2 Turn the ignition key further to position III.

NOTE The engine is always to be started at idling speed.

NOTE If the ignition key remains at position I and the machine has not yet been started or has just been shut off, then:



- The machine goes into standby mode automatically after 10 minutes.

It is possible at any time to start the machine via the transmitter, using the cable operation mode or via the ignition switch.

NOTE If the ignition key remains at position I and the machine has not yet been started or has just been shut off, and no function is activated within 4 hours, then:



- The machine controller shuts itself off completely.

To be able to start the machine, the ignition key must first be moved to position 0 briefly.

7.3 Driving and braking

7.3.1 Position of the operator

Distance to roller:

< 6.5 ft (2m) Operation is not possible.

> 13 ft (4m) Cable is too short, operation is not possible (do not overstretch the cable).

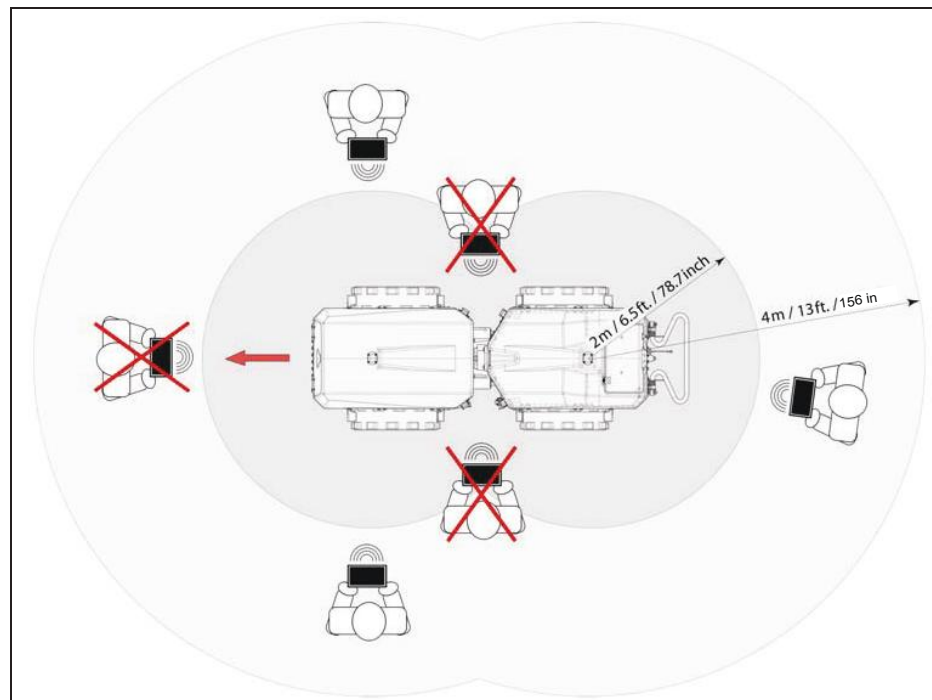

Fig. 7-3 Position of the operator/Distance to roller

Overview of functions	
Operation with the cable	Operation with the infrared sensor
Automatic pairing	
Steering functions	
Vibration functions	
max. range = 13 ft (4 m)	max. range = 65 ft (20 m)
Close proximity shutdown, 6.5 ft (2 m)	

Controller opening angle

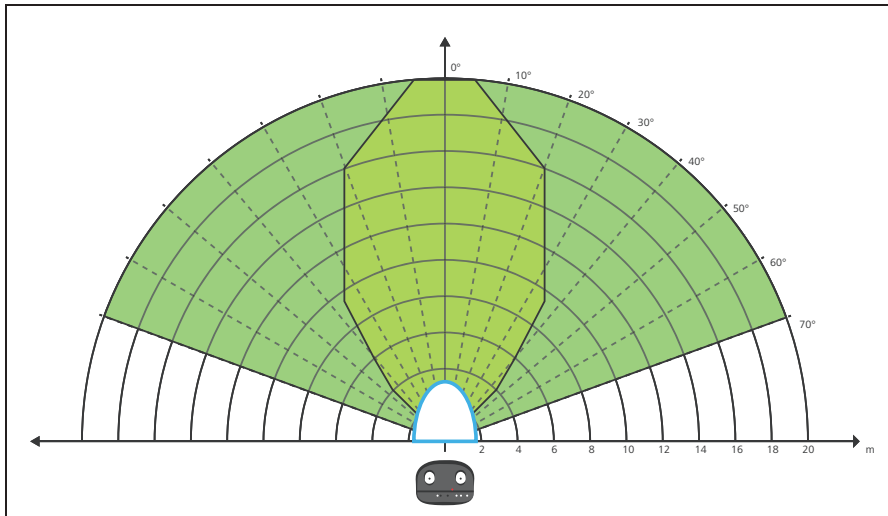

Fig. 7-4 Controller opening angle

NOTE

After a function has been executed, the engine speed is automatically increased to the working speed. If no function is executed for 15seconds, the engine speed is automatically reduced to idling speed.

7.3.2

Driving forwards/backwards

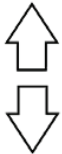

- 1 Move the switch:
- 2a **Toward the front:** The roller moves forward.
- 2b **Toward the rear:** The roller moves backward.

7.3.3

Steering left/right

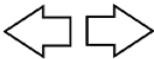

- 1 Move the switch:
- 2a **Toward the left:** The roller moves left.
- 2b **Toward the right:** The roller moves right.

7.3.4

Work gear/Transport gear

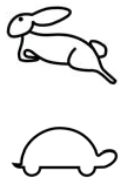

The roller is equipped with two gears.

- 1 Move the switch:
- 2a **Toward the top (rabbit):** the hydraulic system switches to the "transport gear" drive level. The roller drives at a high speed.
- 2b **Toward the bottom (0):** the hydraulic system switches to the "working gear" drive level. The roller drives at a low speed.

NOTE

Please also bear the following in mind:

- When large/small vibration is switched on, it is only possible to drive in the working gear.
- When the machine is cold, the difference between high speed and low speed is minimal.

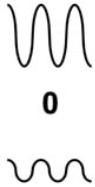
7.3.5***Large/small amplitude vibration***

1 Move the switch:

2a **Toward the top:** The roller vibrates with a large amplitude.

2b **To the center:** The roller does not vibrate.

2c **Toward the bottom:** The roller vibrates with a small amplitude.

	WARNING
	Danger to life through slipping or caving in of the roller! <ul style="list-style-type: none">• Do not use vibration on steep embankments or at steep angles!• Do not vibrate inside buildings and on unstable ground!

NOTE

Damage to material due to harsh vibration movement.

- Never use vibration while at a standstill! If the large/small vibration function is activated for more than 15seconds while at a standstill, the machine controller shuts it off automatically.
- When first started, it is only possible to use the small amplitude vibration function for the first 2minutes.

7.4**Safety and monitoring equipment****7.4.1*****Brake***

The machine is equipped with an hydraulic service brake. It is switched on automatically when no function is being executed.

NOTE

When a function is once again performed, there may be a jerking movement. This has no effect on the stability of the machine.

7.4.2***Close proximity and distant shutdown***

The close proximity and distant shutdown function is an electronic safety feature designed to prevent the operator from loosing visual contact with the machine and to keep it from coming to close.

All of the distance values indicated are measured between the front or back infrared sensor and the infrared transmitter.

The table below shows the approximate distance values for this feature.

Tab. 7-1 Distance values for close proximity and distant shutdown

	Cable operation	IR operation
Close proximity shutdown	approx. 6.5 ft (2 m)	approx. 6.5 ft (2 m)
Distant shutdown	approx. 13 ft (4 m)	approx. 65 ft (20 m)

NOTE

The distance values can vary in dependence on weather conditions. If the maximum range is exceeded in infrared operation/cable operation, the diesel engine continues to idle, but the functions are interrupted. Reduce the distance to the machine in order to resume control of it.

7.5 Turning off the engine

- 1 Move the switch on the infrared transmitter to "STOP".
- 2 Turn the ignition key to the "0" position.

	⚠ CAUTION
	<p><i>As long as the "Start-Stop" rocker switch is placed in the "neutral" position, the transmitter remains operational.</i></p> <ul style="list-style-type: none">• Always switch off the transmitter during work breaks and after completing work by moving the rocker switch to the "Stop" position.

8.1 Shutdown bar (OPTIONAL)

The shutdown bar is located on the rear of the machine under the operating unit. A proximity switch is located on the rear section of the machine above the attachment point of the shutdown bar. If the machine moves against an obstacle with the shutdown bar, the shutdown bar is actuated and triggers the proximity switch. This sends a signal to the machine controller and the machine can now only be moved forward away from the obstacle. If the vibration function is running, it will be shut down. The vibration function must be restarted manually after the shutdown bar has been deactivated. The shutdown bar must be secured with the transport strap for transportation (transport position).



Fig. 8-1 Shutdown bar

- 1 Shutdown bar
- 2 Securing point for strapping down the shutdown bar
- 3 Proximity switch

9.1

General safety information



Maintenance **may only** be carried out by **trained personnel!**

- Only perform maintenance and repair work on the roller if it is static and secured from rolling away.
- Secure the roller with the joint protection.
- Relieve pressure before working on the hydraulic pipes.
- Disconnect the battery before commencing work on the roller's electrical systems.
 - Cover the battery with isolating material or remove it completely. This does not apply to work requiring an electric current.
 - In the event of injuries caused by acid, rinse immediately with clean water and consult a doctor.
- Replace all protection devices properly after performing maintenance and repair work.

	⚠ DANGER
	<p>Danger to life through an unsafe work area!</p> <ul style="list-style-type: none">• Always use an accident-proof support when working on a raised roller.• Never work below a roller which is only supported by a crane or other electrical/hydraulic lifting device.• Only stand under a raised roller if it has been mechanically secured.• Only use stable loading ramps suitable for the weight of the roller for loading.• On transport vehicles, correctly secure the roller against rolling, slipping and overturning.

	⚠ DANGER
	<p>Gas poisoning through letting engine run in enclosed spaces!</p> <ul style="list-style-type: none">• Do not leave the engine running in closed areas.• If use of the roller in a confined space cannot be avoided, the exhaust fumes must be extracted directly from the exhaust pipe.

	⚠ DANGER
	<p>Danger of scalding from hot water / steam!</p> <ul style="list-style-type: none">• Never remove the expansion cap or radiator cap while the engine is running or hot!• First loosen the cap to the first stop to release the pressure. Only then remove the cap.

	⚠ DANGER
	<p>Danger of severe injury through loose clothing being caught and drawn in!</p> <ul style="list-style-type: none">• Only open the engine hood when the engine is switched off.• If trouble shooting makes working on moving parts (engine or roller) unavoidable, never wear: necklaces, bracelets, rings, scarves, ties or other loose items of clothing. <p>If any of these get caught in moving parts there is a danger of serious injury!</p>

	⚠ WARNING
	<p>Danger of scalding from hot water / steam!</p> <ul style="list-style-type: none">• Only work on a cool engine.• Keep enough distance to the exhaust.

	⚠ CAUTION
	<p>Environmental hazard through operating materials!</p> <ul style="list-style-type: none">• Do not allow any liquids to enter drains, the soil or the environment.

NOTE

Damage to electrical controls through contact with water!

- Never spray a water jet into electrical or electronic components.
- Never spray into the engine combustion air intake.

NOTE

**Damage to hydraulic controls through use of wrong oil!
Hydraulic tubes decompose.**

- It is forbidden to change used rollers for use with biodegradable hydraulic oils!
- If hydraulic hoses on a roller running on synthetic ester HE need replacing, only those declared by the supplier as being compatible with synthetic esters may be used.

9.1.1

Battery safety instructions

	⚠ DANGER
	<p>Risk of serious injury through leaking battery acid!</p> <p>The sulfuric acid in the battery is poisonous and so strong it can burn holes in clothes and dissolve skin. If it gets into eyes it can lead to blindness.</p> <ul style="list-style-type: none">• Protect the battery from fire, flames and sparks.• Protect the battery from mechanical damage.

	⚠ DANGER
	<p>Risk of explosion when charging battery!</p> <ul style="list-style-type: none">• Never check the battery charge level with a metal object. Use a voltmeter or the battery's charge indicator.• When disconnecting the battery always disconnect the negative terminal first (-).• Connect the positive terminal (+) first when reconnecting.

NOTE

Doing welding work on the roller when the battery is installed can damage the electrical controls!

- Always remove the battery completely before performing welding work on the roller.

NOTE

Always replace the battery with a service-free battery. If you are using a battery that requires maintenance, always observe the safety instructions in the battery manual.

9.2

General information about maintenance

NOTE

Not all maintenance tasks are listed in these operating and maintenance instructions. We would also like to point out the separate manual for the Yanmar engine.

- When carrying out maintenance work always observe the applicable safety regulations in the 3 *Safety information* section.
- Maintenance work and inspections must be performed according to the following maintenance tables in order to guarantee reliable roller operation.
- Remove all dirt before taking off any covers, plugs, measuring rods, etc. to inspect or top up engine oil, hydraulic oil, diesel or other liquids.
- Any parts that do not pass the following inspections must be replaced immediately.

The protective devices must be correctly refitted after every service.

9.3 Rammax 1575 maintenance

9.3.1 Maintenance plan

Maintenance intervals in operating hours [h] and in calendar periods [daily, weekly, monthly, quarterly, semi annually, annually]	Check, inspect, test, correct, set up					Chapter / D = information from dealer
	Clean, drain					
	Lubricate, treat					
Exchange, replace					Object, condition	
10 1 day	50 1 week	100 1 month	250 3 months	500 6 months		
•	•					9.10
•		•				-
•			•		•	-
•					•	9.8
•					•	9.11.2
•					•	9.7
•					•	9.9
•					•	9.11.1
	(•) 1st		(•) 2nd	•		9.8.4
	•				•	9.13
		•			•	9.12
			•		•	-
				(•) 1st	•	9.9.6
				(•) 1st	•	9.9.5

9.5 Opening the hood, front and rear

⚠ DANGER	
	<p>Danger of severe injury through loose clothing being caught and drawn in!</p> <ul style="list-style-type: none">• Only open the engine hood when the engine is switched off.• If trouble shooting makes working on moving parts (engine or roller) unavoidable, never wear: Necklaces, bracelets, rings, scarves, ties or other loose items of clothing. If any of these get caught in moving parts there is a danger of serious injury!

⚠ WARNING	
	<p>Danger of scalding from hot water / steam!</p> <ul style="list-style-type: none">• Only work on a cool engine.• Keep enough distance to the exhaust.

There is one locking device each on the front and back as well as the left and right of the roller.

- 1 Open both catches, on the right and the left.
- 2 Open the hood.
 - 2.1 Lift the hood with slight pressure toward the center of the roller.
 - 2.2* If the hood is defective, replace it immediately.



Fig. 9-1 Locking device

NOTE

Two gas struts reduce the force required to open the hood and give it its final position. If you need more force to open the hood, replace the gas absorbers. See *When replacing fuses, do not mix them up.*

9.6 Engine compartment overview

9.6.1 Left side of the engine

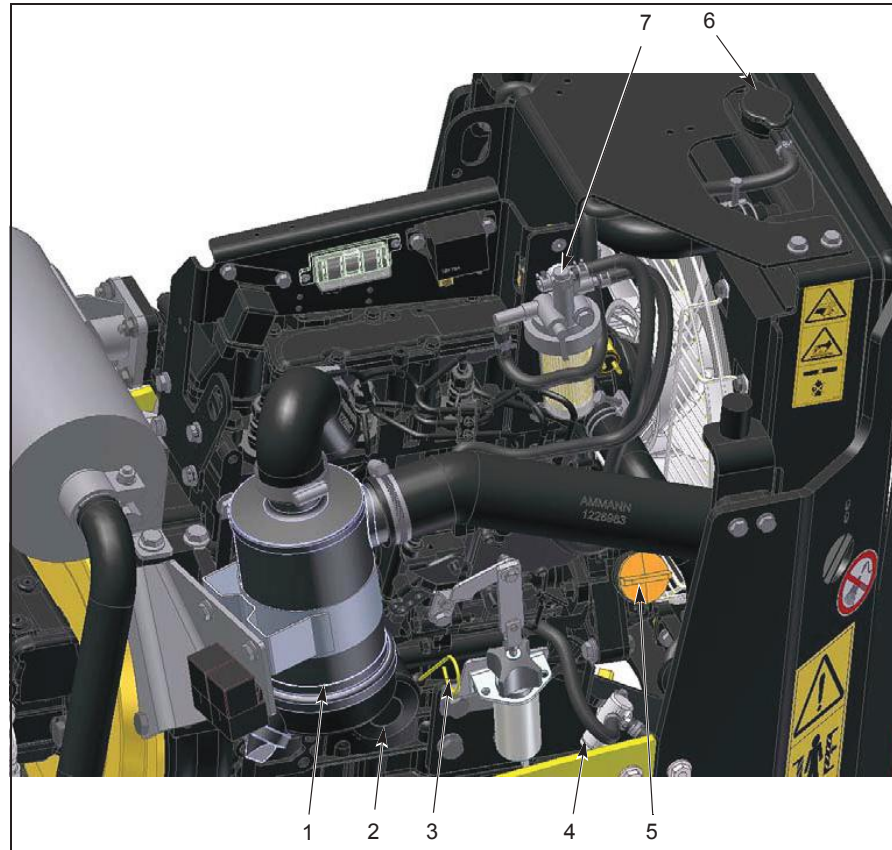

Fig. 9-2 Left side of the engine

- 1 Air-intake filter
- 2 Engine oil filter
- 3 Oil dipstick
- 4 Coolant drain
- 5 Engine oil filler neck
- 6 Coolant filler neck
- 7 Fuel filter

9.6.2

Right side of the engine

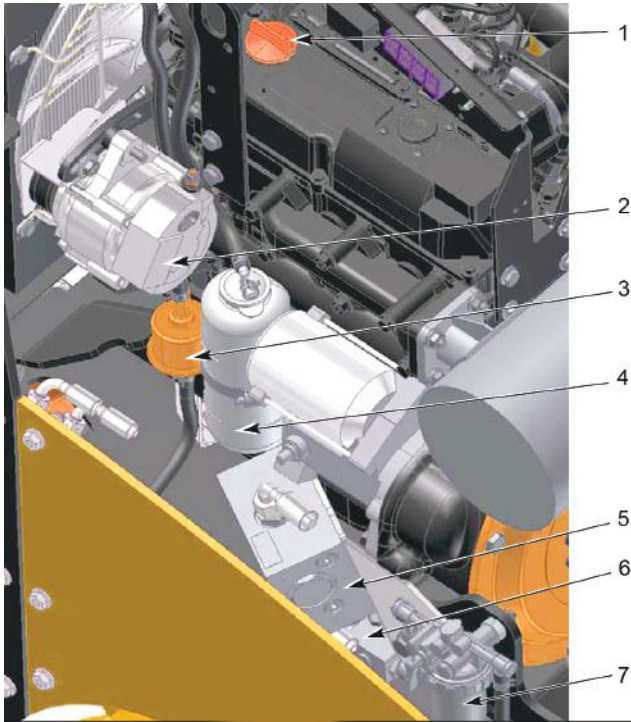

Fig. 9-3 Right side of the engine

- 1 Engine oil filler neck
- 2 Alternator
- 3 Fuel pump
- 4 Coolant level display
- 5 Flow divider
- 6 Nozzle block
- 7 Water separator

	⚠ WARNING
	<p>Risk of burning and injury when handling parts in the engine compartment!</p> <ul style="list-style-type: none">• Switch the diesel engine off when performing any inspection work. The locking brake is active when the diesel engine is switched off.

9.7 Fuel (diesel)

9.7.1 Checking fuel level

- 1 Open the hood.
- 2 Check the level in the plastic tank.

9.7.2 Refueling

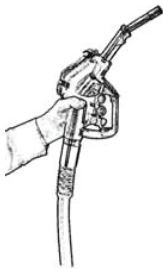

- 1 Fill the fuel tank with diesel fuel up to the lower edge of the filler neck.
- 1a Every day before beginning work

The tank holds 28 liters of diesel fuel.



Fig. 9-4 Diesel fuel filler neck

Diesel Specifications



Tab. 9-1 Excerpt from the Yanmar engine manual about diesel specifications

Diesel specifications	Application
No. 2-D, No. 1-D, ASTM D975-94	USA
EN 590:96	Europe
ISO 8217 DMX	International
BS 2869-A1 or A2	Great Britain
JIS K2204 grade no. 2	Japan
KSM-2610	Korea
GB252	China

NOTE

Poor quality diesel can:

- Reduce the performance of the engine
- Damage the engine

NOTE

For more detailed information, please see the Yanmar engine manual.

9.7.3

Draining fuel

	⚠ CAUTION
	Environmental hazard through operating materials! <ul style="list-style-type: none">• Do not allow any liquids to enter drains, the soil or the environment.

- 1 Unscrew the cover screw **(1)** under the roller (AF size27 wrench).
- 2 Place a container under the drain tap.
- 3 Drain off the diesel.
- 4 Install the screw plug **(1)**.
 - 4.1 Tighten the screw connection hand tight.



Fig. 9-5 Diesel drain, rear left on chassis

9.7.4

Cleaning the fuel tank

Over time, condensation water gathers in the fuel tank. It must be drained once a year.

- 1 Unscrew the cover screw **(1)** under the roller (AF size27 wrench).
- 2 Place a container under the drain tap.
- 3 Allow about **1/2 liter** of fluid to drain.

First, the water which has collected on the bottom of the tank will run out.

- 4 Install the screw plug **(1)**.
 - 4.1 Tighten the screw connection hand tight.

9.7.5 Fuel filter element



Fig. 9-6 Fuel filter

Replace fuel filter element (1) according to the maintenance plan.

- 1 Close stop cock (3).
 - 1.1 Move to OFF.
- 2 Unscrew the filter housing (2).
- 3 Remove the old filter element (1).
- 4 Insert new filter element (1).
- 5 Screw the filter housing (2) on.
- 6 Open stop cock (3).
 - 6.1 Move to ON.

9.7.6 Water separator filter element

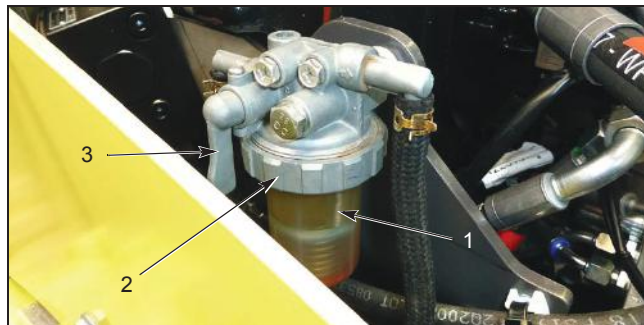

Fig. 9-7 Water separator

Drain filter housing

If there is water in the filter housing, the housing must be drained at once.

- 1 Close stop cock (3).
 - 1.1 Move to OFF.
- 2 Unscrew filter housing and empty.

- 3 Screw the filter housing on.
- 4 Open stop cock (3).
 - 4.1 Move to ON.

Filter element clean

Clean water separator element (1) according to the maintenance plan.

- 1 Close stop cock (3).
 - 1.1 Move to OFF.
- 2 Unscrew the filter housing (2).
- 3 Clean filter element (1).
- 4 Screw the filter housing (2) on.
- 5 Open stop cock (3).
 - 5.1 Move to ON.

9.8 Engine oil

9.8.1 *Checking the engine oil level*

Oil dipstick



- 1 Check engine oil level daily using the dipstick. The dipstick (1) is located on the left of the engine.
 - 1.1 Check oil level while the roller is standing on a level surface and the engine is cold.
 - 1.2 You can see the engine oil level on the dipstick. The oil level must be between the top (x) and bottom (y) marks.
- 2* Top up engine oil as required.



Fig. 9-8 Location of dipstick

9.8.2 *Topping up the engine oil*

- 1 Top up the engine oil at one of the two oil filler necks.
- 1a Filler neck on the left-hand side of the engine.
- 1b Filler neck on the engine.

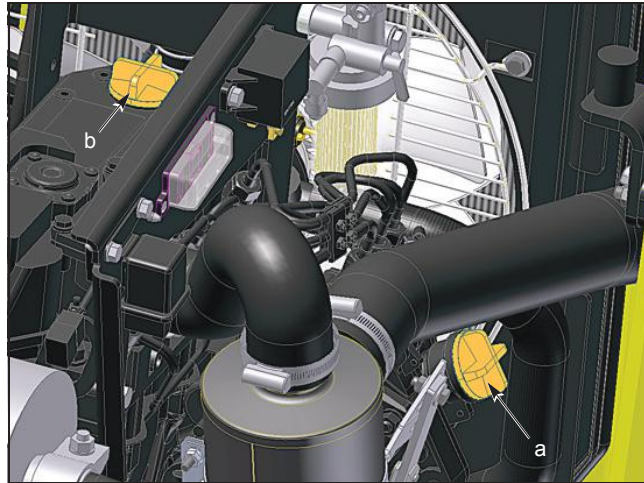

Fig. 9-9 Filler neck to the left and filler neck on top.

NOTE

In order to guarantee operating safety of the engine for the long term, you must not put any additives in the engine oil.

9.8.3 *Draining engine oil*

The engine oil drain (1) is located under the chassis at the front left.

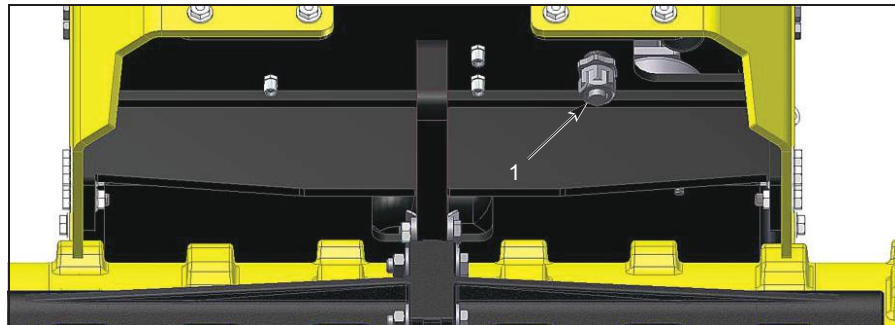



Fig. 9-10 Roller turned fully/ Engine oil drain

	⚠ CAUTION
	<p>Environmental hazard through operating materials!</p> <ul style="list-style-type: none">• Do not allow any liquids to enter drains, the soil or the environment.

- 1 Place a container under the drain.
- 2 Open the union by turning it anti-clockwise (size 27 wrench).

The oil starts to flow out immediately.

9.8.4 **Replace the engine oil filter**



Fig. 9-11 Engine oil filter

- 1 Loosen the filter (1) by hand or using a filter wrench.
 - 1.1 The oil starts to flow out immediately. It's best to place a rag under it beforehand.
- 2 Replace oil filter (2).
- 3 Screw the complete filter back in place.

9.9 **Hydraulic oil**

9.9.1 **Checking the hydraulic oil level**

Inspection window



Always check the hydraulic oil level at operating temperature with the engine running.

- 1 Place the roller on level ground.
- 2 Let the roller continue to idle.
- 3 Check the oil level in the inspection window.
- 4* If the oil level is at the middle of the inspection glass, add 1 liter of hydraulic oil via the filler neck.

9.9.2 **Topping up hydraulic oil**

- 1 Remove the screw lid (1) on the filler neck.
- 2 Add 1 liter of hydraulic oil.

3 Reinstall the screw lid (1).

3.1 Important: Always grease the O-ring before screwing it in place.



Fig. 9-12 Hydraulic oil filler neck

NOTE

Observe the table of lubricants in chapter 9.14.

9.9.3

Draining the hydraulic oil

NOTE

Only drain the hydraulic oil at operating temperature.

- The oil flows better.
- Residues in the tank will be flushed out with the oil.

1 Place a container (with at least a 30 liter capacity) under the hydraulic oil drain.

2 Remove the hydraulic oil tank lid.

3 Unscrew the cover screw (1) under the roller (AF size27 wrench).

4 Allow the oil to drain into the container.

5 Install the screw plug (1).

5.1 Tighten the screw connection hand tight.



Fig. 9-13 Hydraulic oil drain

NOTE

When you drain the hydraulic oil, please also replace the hydraulic oil filter. See chapter 9.9.5.

NOTE Tighten the screw connections in the hydraulic tank hand tight.

9.9.4 *Cleaning the hydraulic oil cooler*

- 1 Check the cooling ribs of the hydraulic oil cooler for dirt and clogging.
- 2 Clean the ribs with water or blow them out with compressed air.

NOTE Never clean the cooler with high pressure (e.g. powerful water jet).



Fig. 9-14 Hydraulic oil cooler grill

9.9.5 *Replacing the hydraulic oil filter*

- 1 Remove the filter lid.
- 2 Unlock the filter element.
- 3 Lift the filter element out of the filter housing.
 - 3.1 Dispose of the filter element in an ecologically appropriate manner.

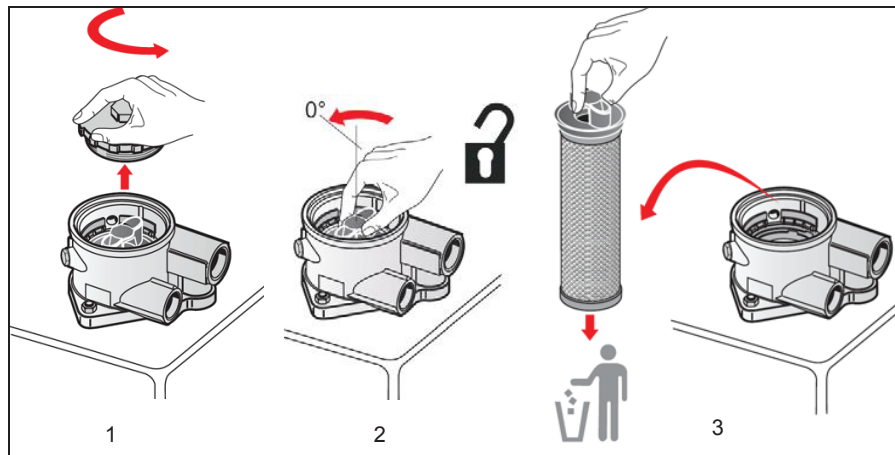

Fig. 9-15 Replacing the hydraulic oil filter, steps 1 to 3

- 4 Place the new filter element in the proper position.

- 4.1 Observe the position of the locking cam.
- 5 Turn the filter element fully clockwise to the stop.

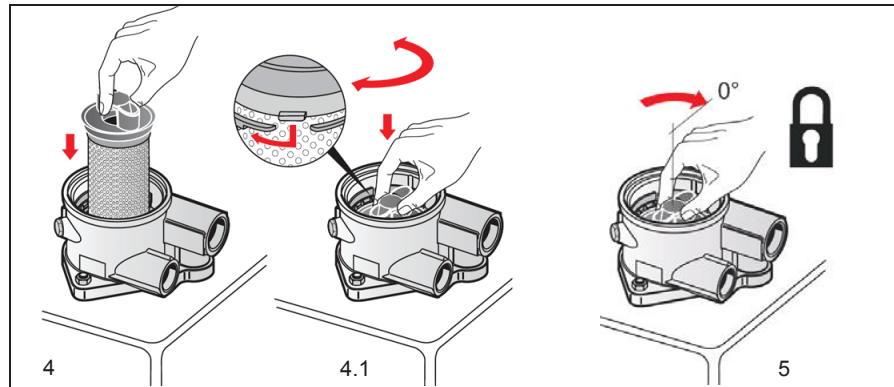

Fig. 9-16 Replacing the hydraulic oil filter, steps 4 to 6

- 6 Lightly oil the sealing ring on the filter lid.
- 7 Put the filter lid in place.
- 7.1 Tighten the lid with a torque wrench (max. torque, 20Nm).

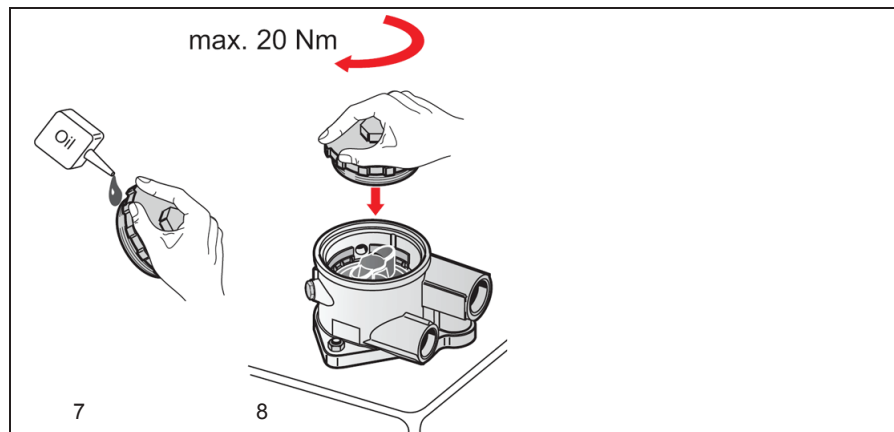

Fig. 9-17 Replacing the hydraulic oil filter, steps 7 to 8

9.9.6 Replacing the ventilation filter



Fig. 9-18 Ventilation filter

Replace the ventilation filter (1) according to the maintenance plan.

9.10 Coolant

A coolant antifreeze mixture for up to -25° is provided upon delivery from the factory. For temperatures colder than -25°, the fluid must be replaced by a suitable coolant antifreeze mixture.

9.10.1 *Checking coolant level*

- 1 Check coolant level every day.
 - 1.1 Check oil level while the roller is standing on a level surface and the engine is cold.
 - 1.2 You can read off the level of coolant on the expansion tank display. The water level must be between the top (FULL) and bottom (LOW) marks.
- 2* Top up coolant as required.

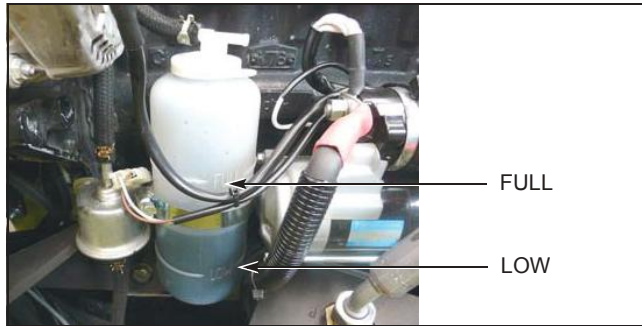



Fig. 9-19 Expansion tank

9.10.2 *Topping up coolant*

	⚠ CAUTION
	<p>Danger of scalding from hot water / steam!</p> <ul style="list-style-type: none">• Only open the tank once the engine and the coolant have cooled down.

- 1 Unscrew the tank lid of the radiator.
- 2 Add coolant with antifreeze until the tank is full.



Fig. 9-20 Coolant filler neck

9.10.3 *Cleaning the radiator*

- 1 Check the cooling ribs of the water tank for dirt and clogging.
- 2 Clean the ribs with water or blow them out with compressed air.

NOTE **Never clean the cooler with high pressure (e.g. powerful water jet).**



Fig. 9-21 Radiator grill

9.11 Functional check

9.11.1 Scrapers

- 640 and 850 1 Before driving, adjust the roller drum scraper so that there is a clearance of about 5mm between the roller drum and the scraper.

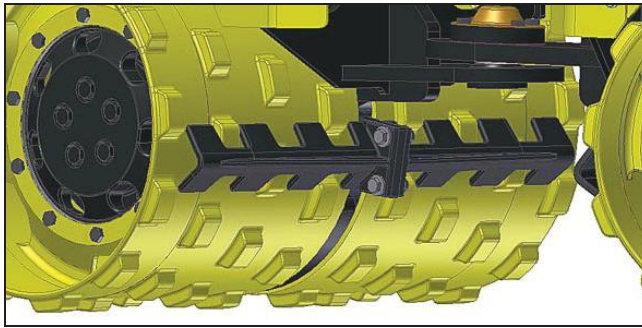

Fig. 9-22 Roller drum scraper

9.11.2 Air-intake filter

- Soiling indicator 1 If a red ring appears on the soiling display (1) during operation of the roller, you must:
- 2a clean the air filter cartridge,
- 3a or replace it.



Fig. 9-23 Soiling indicator

Air filter cartridge The air filter is located on the left side of the engine.

- 1 Remove the wing nut (1) with the cover.
- 2 Remove the wing nut (2) from the air filter cartridge.
- 3 Remove the air filter cartridge (3).
- 4 Check the air filter cartridge for:

5a **Damage:** replace the cartridge.

6a **Soiling:** clean the cartridge.

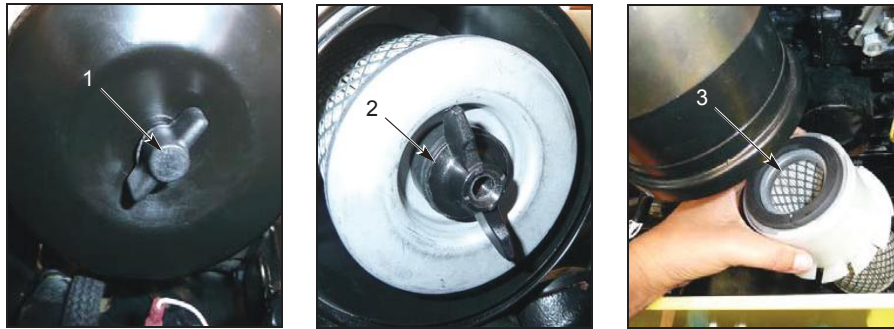

Fig. 9-24 Air filter cartridge

NOTE

If the machine is used on very dusty surfaces, the air filter must be checked for clogging once per week.

- When cleaning/replacing the cartridge, take care that no dirt enters the intake hose.

Air intake

1 Check the air intake for:

1a **Soiling:** clean the intake opening.



Fig. 9-25 Air intake

9.11.3

Pendulum support

Check the pendulum support once a year for excessive play.

1 Attach the roller to a crane (central lifting point).

The play can be checked by alternately applying and releasing upward pressure to the roller (visual inspection).

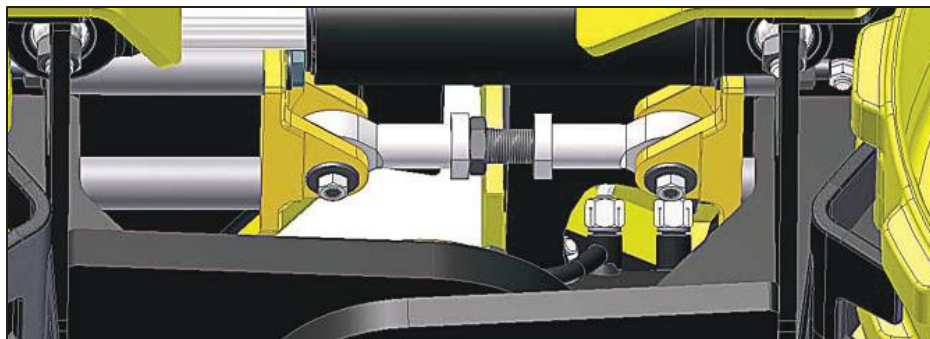

Fig. 9-26 Pendulum support

9.11.4

Articulated joint

Check the articulated joint once a year for excessive play.

- 1 Attach the roller to a crane (central lifting point).

The play can be checked by alternately applying and releasing upward pressure to the roller (visual inspection).

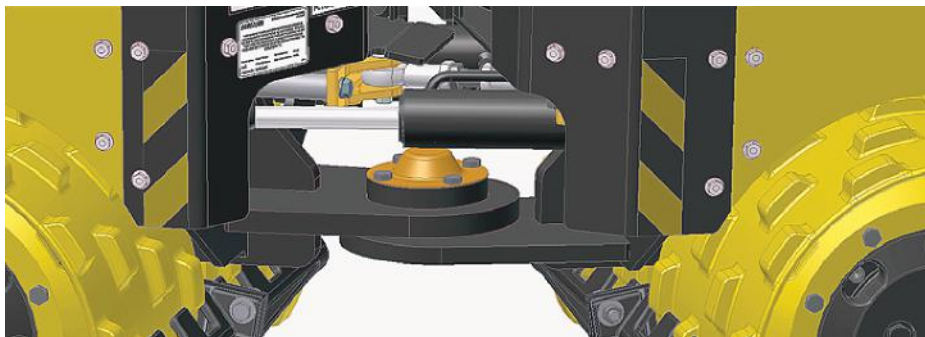

Fig. 9-27 Articulated joint

9.12

Lubricating steering cylinder, bearing



- 1 Rotate the roller's steering fully to the stop in order to grease the cylinder.
- 2 Steer the roller briefly to the right and the left. This causes the bearing to be unloaded.
- 3 Clean the grease nipple (1) before greasing.
- 4 Connect the grease gun to the grease nipple.
- 5 Press grease into the bearing until it visibly begins to ooze out.
- 6 Put the protective cover back on.

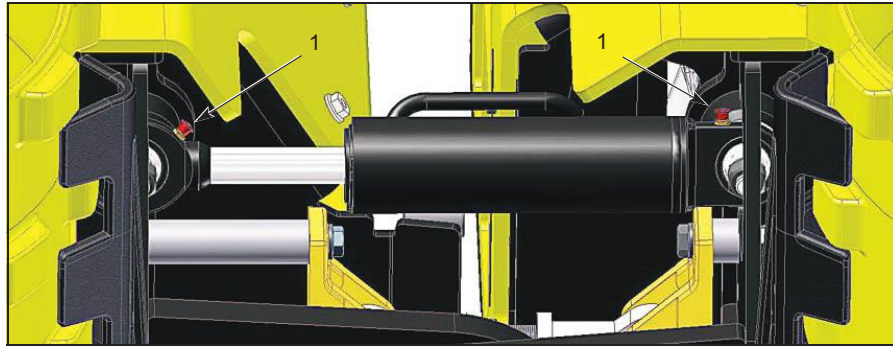

Fig. 9-28 Location of grease nipples on steering cylinder

NOTE

Damager to property due to increased wear!

- Regrease the bearing after every cleaning/steam cleaning of the roller.

9.13 Brake test

The function of the brakes must be checked periodically.

9.13.1 Cable/connector Y9

The cable/connector Y9, which must be disconnected for the brake test, is located at the front under the hood.



Fig. 9-29 Cable/connector Y9 under the hood

9.13.2 Brake test



Fig. 9-30 Cable/connector Y9 under the hood



- 1 Put the machine into the work gear.
- 2 Disconnect connector Y9 (1) from the connector housing at the magnet.
- 3 Perform the forwards and backwards driving functions using the infrared sensor.
- 4 Check all four roller drums for rotation (slipping).

If a brake is defective, the corresponding roller drum will rotate.

NOTE

If a brake is defective, the roller is no longer safe for operation. Contact your authorized dealer and have the roller repaired professionally.

9.14 Lubricant table

Tab. 9-2 Lubricant table

Brand	Hydraulic oil	Synthetic hydraulic oil based on HE esters	Grease
Standard	ISO VG 46 HVLP DIN 51524 T3	ISO 15380 HEES	ISO 2137 DIN 51502
Application	Drive and vibration hydraulics	Drive and vibration hydraulics	
AGIP	Amica 46		
BLASER	Blasol 148		Foodgrease SPM00 (Rammax vibro bearing)
BP	Bartran HV 46		
CASTROL	Hyspin AWH 46		
ESSO	Univis HP 46		
MOBIL	Mobil DTE15		
Motorex	Corex HV 46		MOLY 218 (steering cylinder)
PANOLIN	HLP Universal 46	HLP Synth 46	
SHELL	Tellus T 46		
TOTAL	Equivis ZS 46		

NOTE

Using the wrong oil can cause damage to the hydraulic controls! Hydraulic tubes decompose.

- It is forbidden to change used rollers for use with biodegradable hydraulic oils!
- If hydraulic hoses on a roller running on synthetic ester HE need replacing, only those declared by the supplier as being compatible with synthetic esters may be used.

9.15 Consumables

Tab. 9-3 Consumables

Designation	Brand	Quantity	Art.no.
Engine oil	Motorex Focus CF SAE 10W/40	1l	1242375
Grease	Motorex Moly 218	400g	1111368
Grease	Motorex 174	0.85 kg	1144019
Grease	Blaser Foodgrease SPM00	0.38 kg	1094392
Blue adhesive	Ergo 4052	50ml	1-907977
Red adhesive	Ergo 4100	50ml	1-907978
Paint spray	RAL dark gray	400ml	1202234
Paint spray	RAL 1016 Sulfur yellow	400ml	1-922700
Paint spray	RAL 6033 Mint turquoise	400ml	1-922701
Sealant	Ergo 4207	250g	1-923054

NOTE

The screws can loosen due to the vibration of the roller!



- Unless otherwise specified, secure all screws with blue thread-lock.

9.16 Tightening torques

The values below apply:

- Unless otherwise specified in the operating manual or in the workshop manual
- To female steel threads

9.16.1

Screws



Tab. 9-4 Tightening torque: Hex screws/bolts (including tapping screws) and hexagon-socket-head screws

AF size hex	AF size Allen	Screw diameter	Steel quality	Tightening torque in Nm
7	3	M4	8.8	3
8	4	M5	8.8	6
10	5	M6	8.8	10
13	6	M8	8.8	25
13	6	M8	10.9	36
15		M10x1.25	10.9	90

AF size hex	AF size Allen	Screw diameter	Steel quality	Tightening torque in Nm
17	8	M10	8.8	48
19	10	M12	8.8	84
19	10	M12	10.9	123
24	-	M16	8.8	206

Tab. 9-5 Tightening torque Extremely low-profile cylinder screws and flister-head screws

SW Allen	Screw diameter	Steel quality	Tightening torque in Nm
3	M6	10.9	6
4	M8	10.9	13

Tab. 9-6 Tightening torque Flanged oval-head screws

SW Allen	Screw diameter	Steel quality	Tightening torque in Nm
3	M5	10.9	5

Tab. 9-7 Tightening torque Countersunk head screws

SW Allen	Screw diameter	Steel quality	Tightening torque in Nm
5	M8	10.9	16

9.16.2

Threaded adapters/Metric threads

Tab. 9-8 Tightening torques for threaded adapters/metric threads

Thread size	Cutting ring		Soft seat ring		Nominal joint size	
M10x1.0	18	Nm	18	Nm	6	L
M12x1.5	25	Nm	25	Nm	8	L
M14x1.5	45	Nm	45	Nm	10	L
M16x1.5	55	Nm	55	Nm	12	L
M18x1.5	70	Nm	70	Nm	15	L
M22x1.5	125	Nm	125	Nm	18	L
M26x1.5	180	Nm	180	Nm	22	L
M33x2.0	310	Nm	310	Nm	28	L
M12x1.5	35	Nm	40	Nm	6	S
M14x1.5	55	Nm	40	Nm	8	S
M16x1.5	70	Nm	70	Nm	10	S

Thread size	Cutting ring		Soft seat ring		Nominal joint size	
M18x1.5	110	Nm	90	Nm	12	S
M20x1.5	150	Nm	125	Nm	14	S
M22x1.5	170	Nm	135	Nm	16	S
M27x1.5	270	Nm	180	Nm	20	S

9.16.3 Threaded adapters/Inch threads

Tab. 9-9 Tightening torques for threaded adapters/inch threads

Thread size	Cutting ring		Soft seat ring		Nominal joint size	
1/8"	18	Nm	18	Nm	6	L
1/4"	25	Nm	25	Nm	8	L
1/4"	45	Nm	45	Nm	10	L
3/8"	55	Nm	55	Nm	12	L
1/2"	70	Nm	70	Nm	15	L
1/2"	125	Nm	125	Nm	18	L
3/8"	180	Nm	180	Nm	22	L
1"	310	Nm	310	Nm	28	L
1/4"	35	Nm	40	Nm	6	S
1/4"	55	Nm	40	Nm	8	S
3/8"	70	Nm	70	Nm	10	S
3/8"	110	Nm	90	Nm	12	S
1/2"	150	Nm	125	Nm	14	S
1/2"	170	Nm	135	Nm	16	S
3/4"	270	Nm	180	Nm	20	S

NOTE

To tighten hydraulic hoses and fittings:

- Screw the union nut by hand all the way to the stop, then tighten ¼ of a turn with the wrench (90°)

9.17 Cleaning the roller

After completion of work, clean the roller:

- of major soiling;
- and the lower scrapers of deposits.

Regularly clean completely; at least once a week.

	⚠ DANGER
	<p>Danger to life through runaway roller. Persons standing in the vicinity can be rolled over!</p> <ul style="list-style-type: none">• Before cleaning the roller, be absolutely certain to secure it against unintentional rolling away.

NOTE

While cleaning, observe the following:

- Do not use aggressive or flammable cleansing agents (e.g. gasoline or inflammable substances).
- Only work with the engine turned off.
- Do not directly subject electrical components or isolating materials to a steam jet when using a steam cleaner. Always cover these materials.
- When washing the roller, ensure that no water is sprayed into the air-intake filter.
- Before cleaning the roller with pressure cleaners using water, steam, etc., cover all openings into which the cleaning agent may penetrate. Remove these dummy flanges after cleaning the roller.

10.1 Battery

NOTE

Risk of cable fire or short circuit.

Keep to the proper sequence when removing or installing the terminal connections.

- Ignition on = battery voltage. The battery voltage should not fall below 10 volts while starting, otherwise the battery must be charged.
- Machine running = alternator charging voltage. The voltage should lie in a range of from 13 to 14.5 volts.

10.1.1 Replacing the battery



- 1 Loosen the (-) terminal and disconnect it (size 13).
- 2 Loosen the (+) terminal and disconnect it (size 10).
- 3 Loosen and remove the mounting bracket.

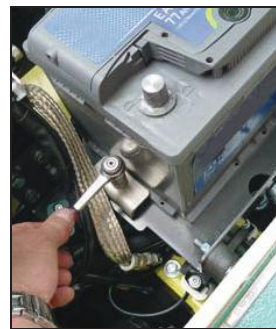

Fig. 10-1 Loosening the terminals

- 4 Lift the battery out of the engine compartment.
- 5 Set the new battery in place.
- 6 Connect the battery.
 - 6.1 Begin with the (+) terminal.



Fig. 10-2 Replacing the battery

NOTE

The battery poles and terminals must be clean. If they are coated with a (whitish or greenish) sulfur crust they must be cleaned.

10.1.2***Starting with another battery (jumping)***

- 1 Connect the red cable to the (+) terminals of both batteries.
- 2 Connect one end of the green or black cable to the (-) terminals of both batteries.
- 3 Actuate the starter. Allow the engine to run.
- 4 Wait until the engine is idling smoothly and then disconnect the cables.
 - 4.1 Begin with the (-) terminal.

NOTE

The battery poles and terminals must be clean. If they are coated with a (whitish or greenish) sulfur crust they must be removed and cleaned.

10.1.3***Charging the battery using a battery charger***

- 1 Disconnect the battery.
- 2 Connect the battery charger.
 - 2.1 Observe the battery charger manufacturer's manual.
- 3 Start with the (+) terminal when reconnecting the battery.

NOTE

The battery poles and terminals must be clean. If they are coated with a (whitish or greenish) sulfur crust they must be removed and cleaned.

10.1.4***Long-term storage***

Remove the negative battery cable from the battery if a standstill period of more than two weeks is expected.

10.2**Fuses**

	⚠ DANGER
	<p>There is danger to life if the roller does not stop in hazardous situations!</p> <ul style="list-style-type: none">• Fuses and safety switches must never be shorted.

	⚠ CAUTION
	<p>Risk of injury through short circuit and cable fire when handling electrical parts!</p> <ul style="list-style-type: none"> • Always disconnect the power supply when working on the electrical system.

NOTE

Before replacing the fuse, you must identify and remove the cause of the fault.

Always replace a defective fuse (1) with a functioning fuse (2) of the same amperage (according to the label or color of the fuse).

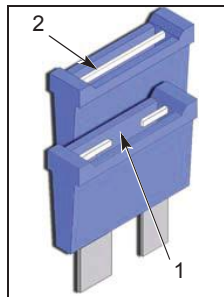

10.2.1

Engine compartment fuses

The fuses are located above the diesel engine.

Tab. 10-1 Engine compartment fuses

Item	Fuse No.	Power	Fuse-protected circuit
1	F21	40 A	Pull-in solenoid
2	F22	10 A	Diesel pump, alternator
3	F23	40 A	Operating speed
4	F24	40 A	Pre-heating coil

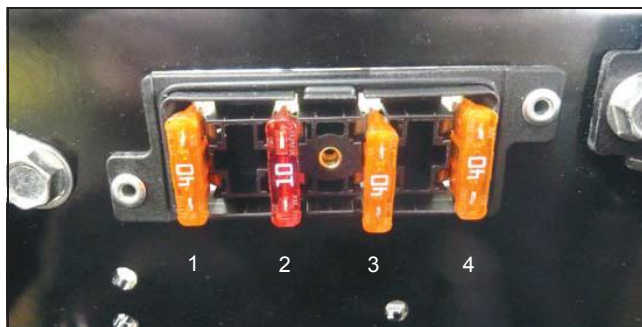

Fig. 10-3 Engine compartment fuses

10.2.2 Cockpit fuses

The fuses are located under the cowling in the cockpit

Tab. 10-2 Cockpit fuses

Item	Fuse No.	Power	Fuse-protected circuit
1	F11	10 A	Controller, power supply
2	F12	25 A	Controller, outputs
3	F13	10 A	Display unit, shutdown bar
4	F14	25 A	Hydraulic oil cooler

Fig. 10-4 Cockpit fuses

NOTE

Faulty installation can cause short circuiting or a cable fire.

- When replacing fuses, do not mix them up.

10.3 Gas strut



Gas struts are maintenance-free! They require no maintenance such as lubrication. They are designed for the respective requirements and work trouble-free for many years.

10.3.1 Replacing gas struts



removal

⚠ WARNING	
	<p>Risk of accident through hood falling down!</p> <ul style="list-style-type: none"> • Secure the hood before you replace the gas struts. <ul style="list-style-type: none"> ○ Support the hood with a rod. ○ Attach the hood to a crane by the handle.

- 1 Use a screwdriver to lift the clips.
- 2 Pull the gas strut away from the ball joint.

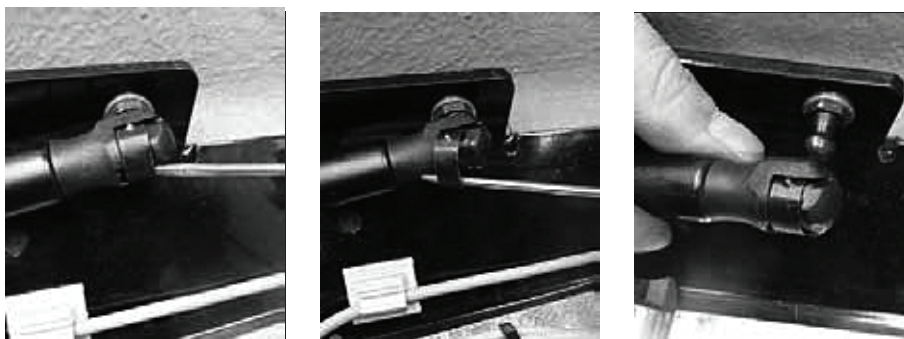

Fig. 10-5 Using a screwdriver, lift the clips and loosen the springs

installing

- 1 The new gas struts can easily be installed by pressing them onto the ball joint.
 - 1.1 The clamp must be seated securely afterward.

NOTE

When reinstalling the gas strut, secure the extended part at the bottom:



Fig. 10-6 Gas strut

NOTE

Gas struts should not be installed if they have been damaged through mechanical manipulation.

- Welding on gas struts as well as dirt or paint on the piston rods can lead to failure of the units.
- Avoid modifications, manipulation, impacts, tensile loading, heating, painting over or removal of imprints.
- Do not install defective or improperly handled products.

NOTE

If gas struts are no longer needed, they must be disposed of in an environmentally appropriate manner. For this purpose, they will be drilled out to allow the compressed nitrogen to escape and to drain the oil they contain. See also *Removal and depressurization of the gas strut*.

10.4 Overturning/Tipping of the Rammax 1575

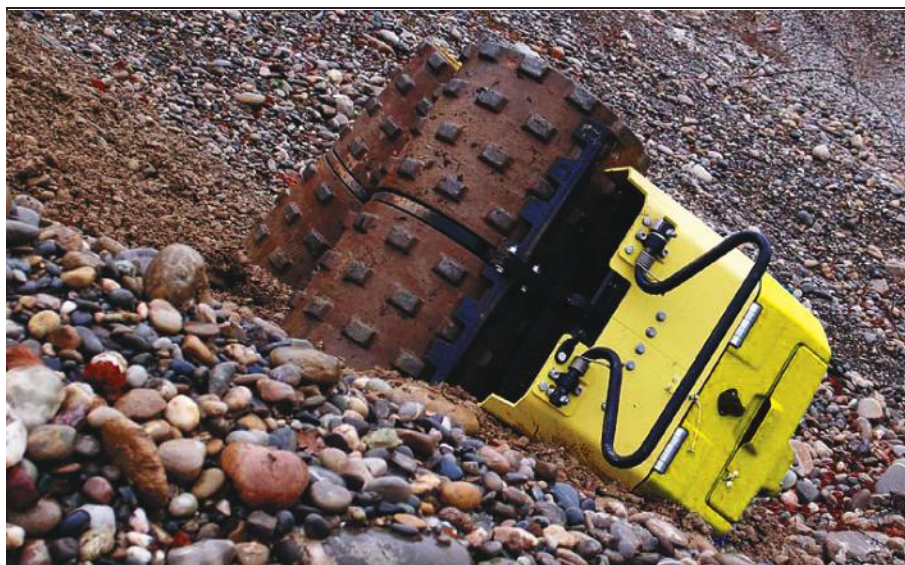

Fig. 10-7 Rammax 1575 overturned

- 1 Place the machine back onto the roller drums as quickly as possible.
- 2 Turn the ignition off (position 0).

NOTE

Do not under any circumstances attempt to restart the engine right away!

- Avoid oil shock!
- Severe engine damage can result!

⚠ CAUTION	
	<p>Environmental hazard through operating materials!</p> <ul style="list-style-type: none"> • Do not allow any liquids to enter drains, the soil or the environment. • Immediately bind any fluids which have leaked out, such as oil, diesel, antifreeze, battery acid!



Fig. 10-8 Rammax 1575

10.4.1 *Inspect for damage*

- 1 Open both hoods.
- 2 Disconnect the ground cable (-).



Fig. 10-9 Disconnect the battery

- 3 Inspect the machine for visible damage.
 - 3.1 Especially for fluids which have leaked out.
- 4 Empty any containers (tanks) which may be defective.

10.4.2 *Prevent an oil shock*

NOTE

Before you begin the dismantling and disassembly of parts, you must thoroughly clean the area around the valve cover, cylinder head and electrical steel.

If no visible damage is found or it has already been repaired, perform the following procedure:

- Removal of parts*
- 1 Remove fuse F21 in the engine compartment.

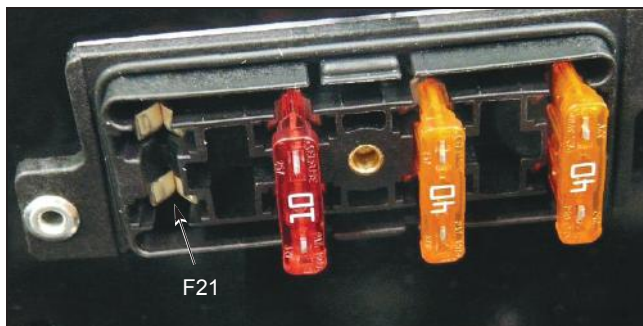

Fig. 10-10 Engine compartment fuses

- 2 Remove the air filter element.
 - 2.1 If it is oily, replace it.
- 3 Clean the air filter housing.
- 4 Disassemble the air filter hose at the top.

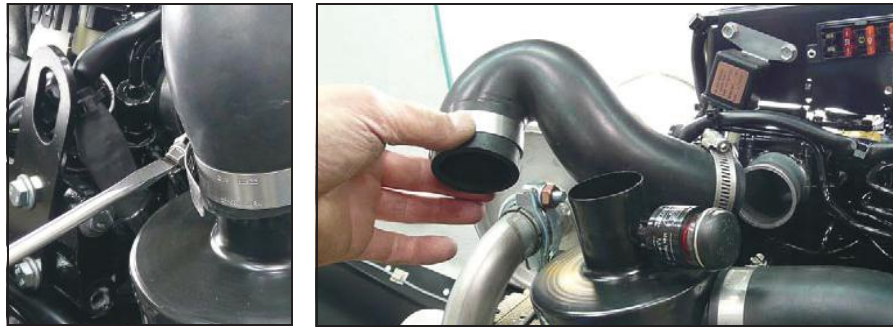

Fig. 10-11 Remove the air filter hose at the top

5 Disassemble the fuel filter (AF size 13).

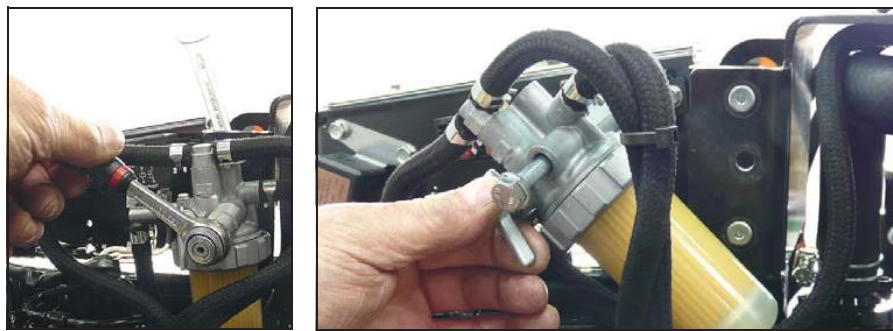

Fig. 10-12 Disassemble fuel filter

6 Disassemble the electrical steel and fold it toward the back.

6.1 Screws at back (2 Allen screws, SW 4).

6.2 Screws at front (4 hex screws, SW 13).

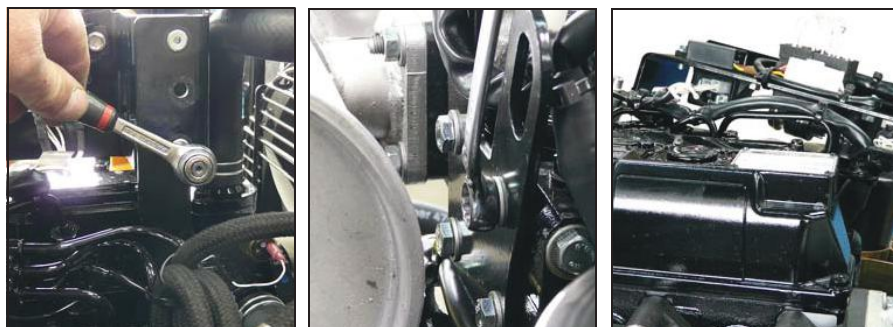

Fig. 10-13 Disassemble electrical steel at back/front

- 7 Disassemble the valve cover (9 hex screws, SW 10).

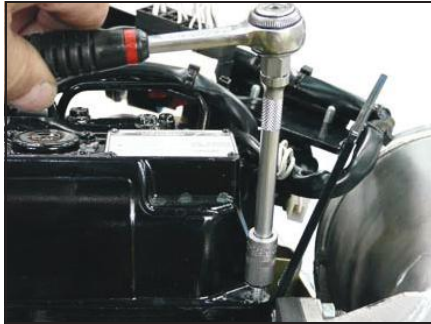

Fig. 10-14 Disassemble the valve cover

- 8 Remove the three cables and contact connectors on the glow plugs (AF size 8).

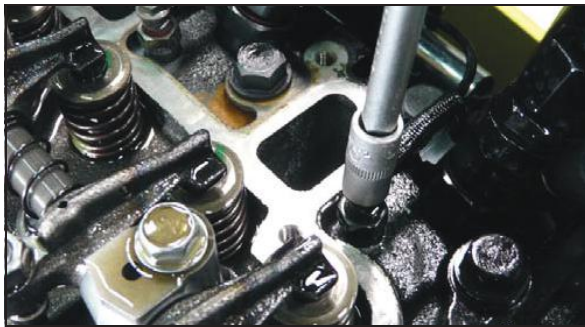

Fig. 10-15 Remove cables and contact connectors

- 9 Remove ALL three glow plugs (AF size 12).

- 9.1 Tools: Long socket (AF size 12) and torque wrench.



Fig. 10-16 Tools/Spark plug removal

Turn the engine over (rotate crankshaft) with a wrench

Ensure that the oil which may have collected is displaced by the piston.

- 1 Turn the engine over twice clockwise by means of the central bolt (AF size 17) on the crankshaft using a box-end ratchet wrench (1).



Fig. 10-17 Box-end ratchet wrench/Rotate crankshaft

NOTE

Risk of cable fire or short circuit.

Insulate the connection cables for the glow plugs, e.g. using a piece of hose.



Fig. 10-18 Insulate the connection cable

- 2 Refasten the electrical steel using two screws (1).



Fig. 10-19 Fasten electrical steel

- 3 Reconnect the battery ground cable (-).

	⚠ WARNING
	<p>Danger of burns due to ejected oil!</p> <p>Eye injury, burns</p> <ul style="list-style-type: none"> • Wear safety goggles

Turn the engine over using the starter

- 1 Turn the engine over using the starter for 1-2 minutes.

After a few revolutions, the oil which has gathered in the combustion chambers should have been pressed out through the openings for the glow plugs.

Repeat the procedure after about 5 minutes. It is essential to be sure that no more oil is present in the combustion chambers!

- 2 Reinstall the glow plugs (AF size 12, torque, 18Nm).



Fig. 10-20 Glow plugs

- 3 Reconnect the contact connectors and cables to the glow plugs (AF size 8, torque, 1.5 Nm).



Fig. 10-21 Connection cable

- 4 Install the valve cover.
- 5 Install the electrical steel.

Turn the engine over with the ignition key

- 1 Turn the ignition key clockwise to position III.
 - 1.1 The engine must turn over.

If this is not the case, do not under any circumstances attempt to start the engine!

It is possible that there could still be oil in the combustion chambers. Repeat the procedure described above, or otherwise contact your authorized dealer right away!

If the engine turns over:

- 1 Check all fluid levels.
 - 1.1 If needed, top up the fluids.
- 2 Put fuse F 21 back in place.

10.4.3 Start the engine

1. *Attempt to start*
- 1 Turn the ignition key clockwise to position III.
 - 1.1a Attempt to start is successful, engine is running: See “Engine is running” further down.
 - 1.1b Attempt to start is unsuccessful, engine is not running: There could be air in the diesel system. See “Check the pump” in the following.

- Check the pump*
- 1 Turn the ignition key clockwise to position I.
 - 1.1 Check whether the electrical fuel pump is working.

Allow the pump to operate for about 1 minute. The system will be bled automatically.

2. *Attempt to start*
- 1 Turn the ignition key clockwise to position III.
 - 2 Allow the engine to turn over in neutral!
 - 2.1 Do not activate any functions.

Engine running The engine will smoke until the oil that has gathered in the exhaust system has been burned away (can take up to 1 h).

	▲ WARNING
	Danger of fire! It is possible for flames/glowing embers to be shot out of the exhaust pipe.

- 1 Immediately perform a visual inspection for any leaking fluids.

If everything is in order:

- 1 Bring the engine up to maximum speed.
 - 1.1 Check the functions.

The smoke from the engine must be decreasing noticeably and then stop completely. Otherwise, there may be a mechanical defect in the engine.

- 1 Switch off the engine.
- 2 Check all fluid levels.
 - 2.1 Top up as needed.
- 3 Inspect for fluid losses.
- 4 Start the engine.

11.1 Storage

11.1.1 Short-term storage

- Move the Start/Stop lever on the infrared transmitter to the neutral position.
- Secure the roller from unauthorized start-up and unintentional rolling away.
- Remove the ignition key.

11.1.2 Long-term storage

Tab. 11-1 Long-term storage

Component	precautions	Chapter
Diesel engine	Observe the information in the "Long-term storage" section in the diesel engine manual.	
Fuel (diesel)	Drain.	9.7.3
Battery	Uninstall the battery and clean the outside. Charge the battery once a month during standstill time.	10.1
Air filter unit, exhaust pipe	Cover the air filter unit or its intake opening and the exhaust pipe with adhesive tape. This prevents moisture from getting into the engine.	
Hydraulic oil level	Drain the hydraulic oil completely. Fill up the hydraulic oil tank with fresh oil when putting the machine back into operation.	9.9
Steering cylinder	Lubricate the bearings of the steering knuckle and the front bearing of the steering cylinder with grease. Lubricate the piston rod of the steering cylinder with grease guard.	9.12
Infrared transmitter	Always move the "Start/Stop" switch to the Stop position.	

12.1 Transport

12.1.1 Shipping weights and dimensions

Tab. 12-1 Shipping weights and dimensions

Roller drum width (mm)	Rammax 1575	
	640	850
Shipping weight (kg)	1400	1450
Dimensions: L x W x H - without shutdown bar (cm)	200 x 64 x 132	200 x 85 x 132
Dimensions: L x W x H - with shutdown bar folded upwards (cm)	205 x 64 x 132	205 x 85 x 132

⚠ DANGER



Risk of crushing through presence in the pivoting area (danger zone)!

- The articulated joint lock (joint protection) must be fitted before lifting the roller for transport.
- Be certain that no persons are present in the area of the joint protection.

12.1.2 Joint protection

Articulated joint blocking

- 1 Release the lower part of the joint protection (1).
 - 1.1 First, remove the compression spring (2) and then the lock bolt (3).
- 2 Carefully turn the roller steering until the joint protection comes in line with the opposite loop.

NOTE

In order to operate the steering, you must start the roller and maintain a distance of at least 2 meters.

⚠ DANGER



Risk of crushing through presence in the pivoting area (danger zone)!

- As soon as the roller is aligned, shut it off again.

- 3 Hook the joint protection into place.
- 4 Secure the joint protection with the lock bolt (3).
- 5 Secure the lock bolt with the compression spring (2).

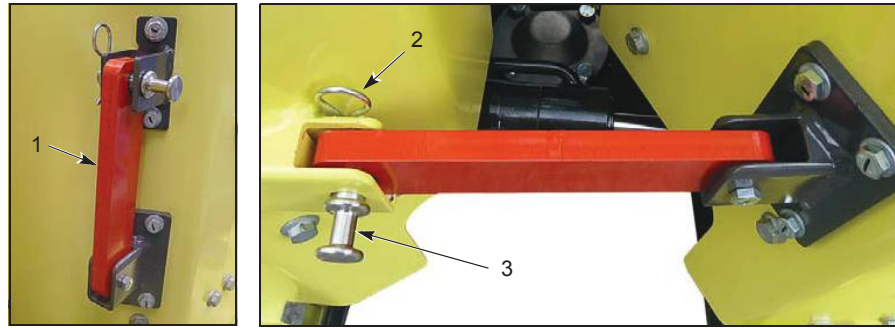



Fig. 12-1 Joint protection open/joint protection locked in place

12.2 1-point lifting eye

12.2.1 Lifting at the 1-point lifting eye

	▲ DANGER
	<p>Crushing hazard!</p> <ul style="list-style-type: none"> • Always lift the roller vertically. • Do not stand under suspended loads! • Use only anti-slip, stable ramps when loading! • Secure the roller on transport vehicles to prevent it from rolling away, slipping to the side or tipping over!

NOTE

The lifting devices (steel cables, etc.) must be dimensioned in accordance with relevant regulations.



- 1 Bring the joint protection into place.
- 2 Lift the roller vertically with suitable hoisting tackle.
 - 2.1 Use suitable lifting equipment.

The 1-point lifting eye is designed for a WLL of 1.6 tons (Working Load Limit).



Fig. 12-2 1-point lifting eye

12.2.2

Securing the roller on the transporter



- 1 Bring the joint protection into place.
- 2 Attach the lashing straps to the lashing rings on the roller and on the truck
 - 2.1 Lashing method: Direct lashing/diagonal lashing as shown in photo
 - 2.2 Use four lashing straps with a permissible tensile force of LC = 2,500 daN

The lashing rings on the roller are designed for a permissible tensile force of 2,500 daN.

Permissible angle ranges for diagonal lashing:

- $15^\circ \leq \alpha \leq 65^\circ$
- $30^\circ \leq \beta \leq 75^\circ$



Fig. 12-3 Lashing the roller/side view

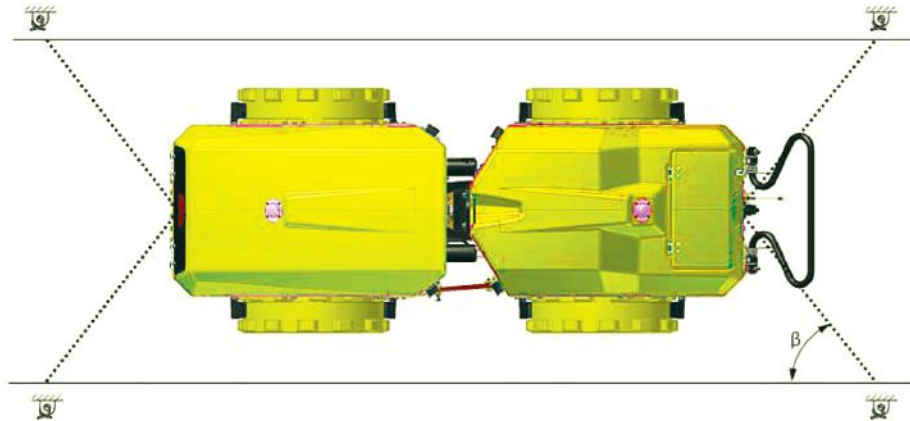

Fig. 12-4 Lashing the roller/front view

	CAUTION
	Risk of accident through blocked steering! <ul style="list-style-type: none">• Open the joint protection before starting the roller.

12.2.3

Center of gravity

The center of gravity relevant to transport is located 460mm from the floor and approx. in the center of the roller, depending on the fill level of the diesel or water tanks.



Fig. 12-5 Roller's center of gravity

13.1 Introduction

	⚠ CAUTION
	Environmental hazard through operating materials! <ul style="list-style-type: none">• Do not allow any liquids to enter drains, the soil or the environment.

The roller must be disposed of properly; ask your authorized dealer.

13.2 Removal and depressurization of the gas strut

	⚠ WARNING
	Eye injury! Because of the high internal pressure, chips and oil can spatter from the site of sawing or drilling. <ul style="list-style-type: none">• Wear eye and face protection.• Cover the site of the saw cut.

	⚠ CAUTION
	Environmental hazard through operating materials! Gas struts are filled with oil. <ul style="list-style-type: none">• Do not allow any liquids to enter drains, the soil or the environment.

In case of disposal, pressurized gas struts must be depressurized according to the following regulations:

- 1 Fasten the pressurized tube between two prismatic jaws without deforming it and in such a way that the dimension X is at least 25mm (see below).
- 2 To depressurize:
 - 2a Slowly cut the pressurized tube open at the points indicated using a **handsaw** or,
 - 2b Drill a hole in the tube using a **drill** with about a 3 mm diameter.

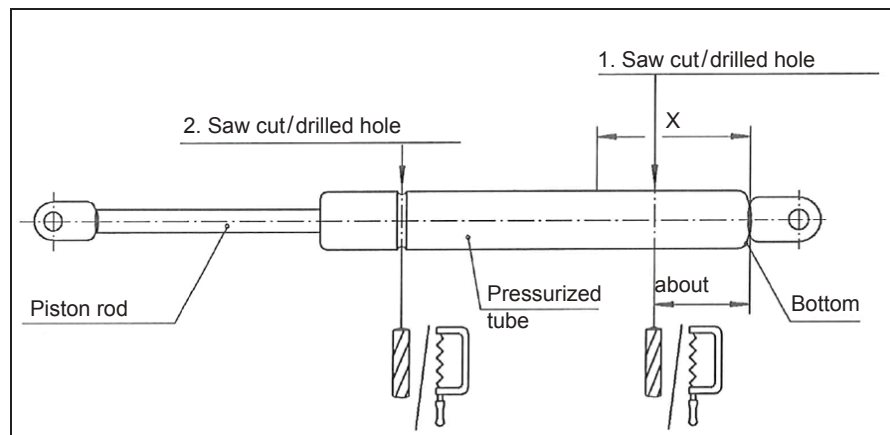

Fig. 13-1 Removal and depressurization of the gas strut

1. Saw cut/hole position: Cut or drill into the pressurized tube about 20 mm from the bottom.
2. Saw cut/hole position: Cut or drill into the pressurized tube in the bead.

NOTE

If disposal according to these regulations is not possible, ask your authorized dealer.

14.1 Rammax 1575 wiring diagram

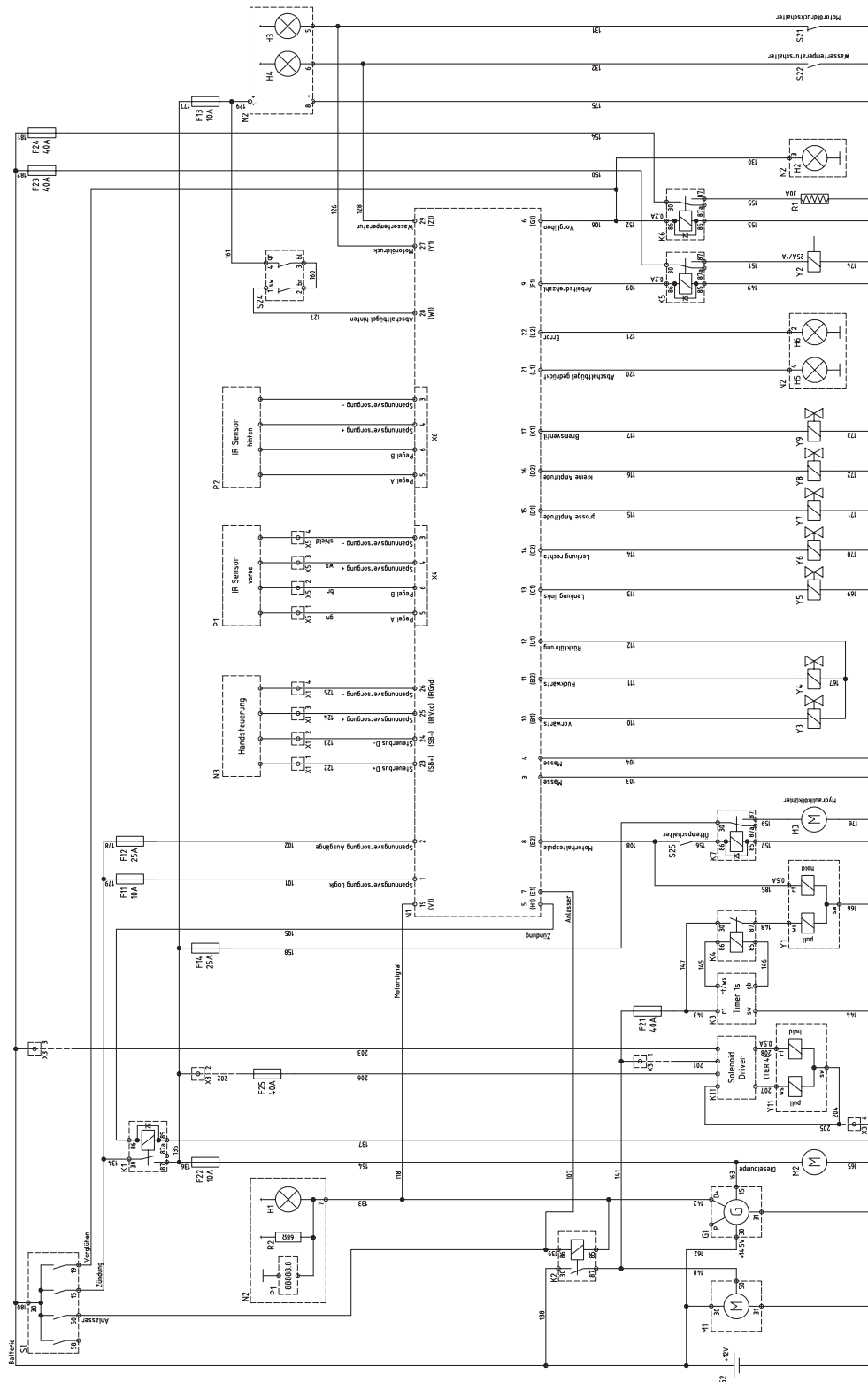

14.1.1

Legend for Rammax 1575 wiring diagram

Element	Description
F11	Fuse, controller, supply
F12	Fuse, controller, outputs
F13	Fuse, display unit, shutdown bar
F14	Fuse, hydraulic oil cooler
F21	Fuse, pull-in solenoid
F22	Fuse, diesel pump, alternator
F23	Fuse, operating speed
F24	Fuse, pre-heating coil
F25	Fuse, "2nd solenoid"
G1	Alternator
G2	Battery
K1	Relay, ignition
K2	Relay, starting interlock
K3	Timer relay
K4	Relay, pull-in solenoid
K5	Relay, operating speed
K6	Relay, pre-heating coil
K7	Relay, hydraulic oil cooler
K11	Relay, "solenoid driver"
M1	Starter motor
M2	Diesel pump
M3	Hydraulic oil cooler
N1	Machine controller
N2	Display unit
N3	Infrared transmitter
P1	Front infrared transmitter
P2	Rear infrared transmitter
R1	Pre-heating coil
S1	Switch, ignition switch
S21	Sensor, engine oil pressure
S22	Sensor, coolant temperature
S24	Sensor, shutdown bar
S25	Sensor, hydraulic oil temperature
Y1	Magnet, pull-in/holding solenoid

Element	Description
Y2	Magnet, operating speed
Y3	Magnet, drive pump, forwards
Y4	Magnet, drive pump, backwards
Y5	Valve, steering, left
Y6	Valve, steering, right
Y7	Valve, large amplitude vibration
Y8	Valve, small amplitude vibration
Y9	Valve, locking brake
Y11	Magnet, "2nd solenoid"

14.2 Rammax 1575 hydraulic circuit diagram

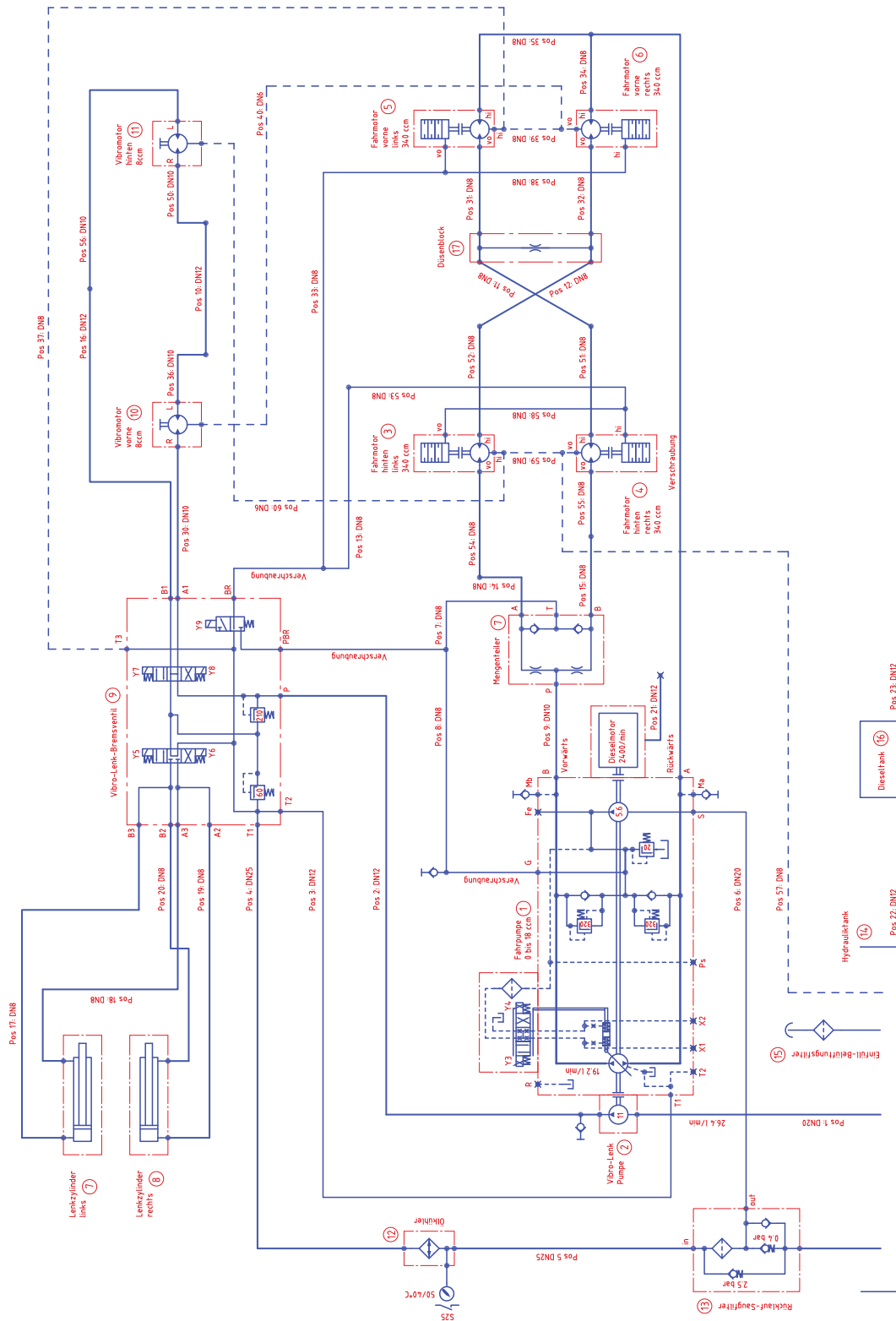

Fig. 14-2 Hydraulics diagram no. 10442344

14.2.1**Legend for Rammax 1575 hydraulic circuit diagram**

Element	Description
1	Drive pump
2	Vibro-steering pump
3	Drive motor, rear left
4	Drive motor, rear right
5	Front left drive motor
6	Front right drive motor
7	Left steering cylinder
8	Right steering cylinder
9	Vibro steering/brake valve
10	Vibro motor, front
11	Vibro motor, rear
12	Oil cooler
13	Return-line suction filter
14	Hydraulic oil tank
15	Filler, ventilation filter
16	Diesel tank
17	Nozzle block

OPERATION MANUAL

HERE'S HOW TO GET HELP

PLEASE HAVE THE MODEL AND SERIAL
NUMBER ON-HAND WHEN CALLING

UNITED STATES

Multiquip Corporate Office

18910 Wilmington Ave.
Carson, CA 90746
Contact: mq@multiquip.com

Tel. (800) 421-1244
Fax (310) 537-3927

Service Department

800-421-1244
310-537-3700

Fax: 310-537-4259

Technical Assistance

800-478-1244

Fax: 310-943-2238

MQ Parts Department

800-427-1244
310-537-3700

Fax: 800-672-7877
Fax: 310-637-3284

Warranty Department

800-421-1244
310-537-3700

Fax: 310-943-2249

CANADA

Multiquip

4110 Industriel Boul.
Laval, Quebec, Canada H7L 6V3
Contact: jmartin@multiquip.com

Tel: (450) 625-2244
Tel: (877) 963-4411
Fax: (450) 625-8664

UNITED KINGDOM

Multiquip (UK) Limited Head Office

Unit 2, Northpoint Industrial Estate,
Globe Lane,
Dukinfield, Cheshire SK16 4UJ
Contact: sales@multiquip.co.uk

Tel: 0161 339 2223
Fax: 0161 339 3226

© COPYRIGHT 2015, MULTIQUIP INC.

Multiquip Inc, the MQ logo are registered trademarks of Multiquip Inc. and may not be used, reproduced, or altered without written permission. All other trademarks are the property of their respective owners and used with permission.

This manual MUST accompany the equipment at all times. This manual is considered a permanent part of the equipment and should remain with the unit if resold.

The information and specifications included in this publication were in effect at the time of approval for printing. Illustrations, descriptions, references and technical data contained in this manual are for guidance only and may not be considered as binding. Multiquip Inc. reserves the right to discontinue or change specifications, design or the information published in this publication at any time without notice and without incurring any obligations.

Your Local Dealer is:

