

HYDRAULIC EXCAVATOR

takeuchi
From World First to World Leader

TB216H



HYBRID

Product Features & Specifications

OPERATING PERFORMANCE

Operating Weight	4,277 lb	(1,940 kg)
Max. Bucket Breakout Force	4,250 lb	(1,928 kg)
Max. Arm Digging Force	1,843 lb	(836 kg)
Arm Length	3 ft 8.5 in	(1,130 mm)
Slew Speed	9.2 rpm	
Traction Force	4,361 lb	(1,978 kg)
Ground Pressure	4.3 psi	
Max. Travel Speed		
Low Range	1.4 mph	(2.2 km / hr)
High Range	2.6 mph	(4.2 km / hr)

HYDRAULIC

Total Hydraulic Flow	13.4 gal / min	(50.9 L / min)
Auxiliary Hydraulic Flow	8.9 gal / min	(33.6 L / min)
System Operating Pressure	3,046 psi	(21.0 mpa)

ENGINE / ELECTRIC MOTOR

Model / Make	Yanmar / 3TNV74
Displacement	60.0 cu in (.99 L)
Max. Torque @ 1,800 rpm	38.2 ft-lb (51.8 Nm)
Output Diesel Engine	14.9 hp 11.1 kW/2,400 rpm
Output Electric Motor	14.2 hp 10.6 kW/2400 rpm
Electrical Connection	400 - 480 V/47 - 63 Hz / Fused w/ min. 32A

FLUID CAPACITIES

Engine Lubrication	4.5 qt	(4.3 L)
Cooling System	4.0 qt	(3.8 L)
Fuel Tank Capacity	5.8 gal	(22.0 L)
Hydraulic Reservoir Capacity	4.2 gal	(16.0 L)
Hydraulic System Capacity	6.5 gal	(24.5 L)



Multi-Informational Display



Retractable Undercarriage



Long Arm with Thumb Mount



Spacious Operator's Station

ENGINE

- U.S. EPA Final Tier 4 Emission Compliant
- Engine Preheat
- Extended Life Coolant
- Dual Element Air Filters
- Automatic Fuel Bleed System

ELECTRIC MOTOR

- 100% Emissions Free Operation
- Variable Frequency Drive

ELECTRICAL

- Multi-Informational Display
- Visual Indicator for Engine Preheat, High Speed, Water Temp and Fuel Gauge
- Function Keys Transition Between Hour / Trip Meter, Time and Alarm, and Contrast Adjustment
- Hour Meter
- Travel Alarm

UNDERCARRIAGE AND FRAME

- Triple Flanged Track Rollers
- Hydraulically Retractable Track Frame
- Two-Speed Travel
- Adjustable Width Backfill Blade
- Cast Iron Wrap Around Protective Counterweight
- 9" Rubber Track

HYDRAULIC

- Variable Displacement Piston Pumps
- Cushioned Boom and Swing Cylinders
- Pilot Operated Joystick Controls
- Hydraulic Oil Cooler
- Steel Hydraulic Tank with Fluid Level Sight Gauge
- Primary Auxiliary Circuit Plumbed to Arm with 1-Way and 2-Way Operation

WORKING EQUIPMENT

- Top Mount Boom Cylinder
- Hydraulic Hoses Protected Inside of Boom and Arm
- Long Arm with Integrated Thumb Mount
- Dual Pin Position Bucket (optional)
- Mechanical Bucket Quick Coupler (optional)
- Main Pin Hydraulic Thumb (optional)

OPERATOR'S STATION

- ROPS / TOPS / FOPS Four Post Canopy
- Pattern Change Valve (ISO or SAE)
- Suspension Seat with Fore and Aft Adjustments
- Auxiliary Hydraulics Controlled with Foot Pedal
- 2" Retractable Seat Belt
- 3" Non-retractable Seat Belt (optional)

TB216H Compact Excavator

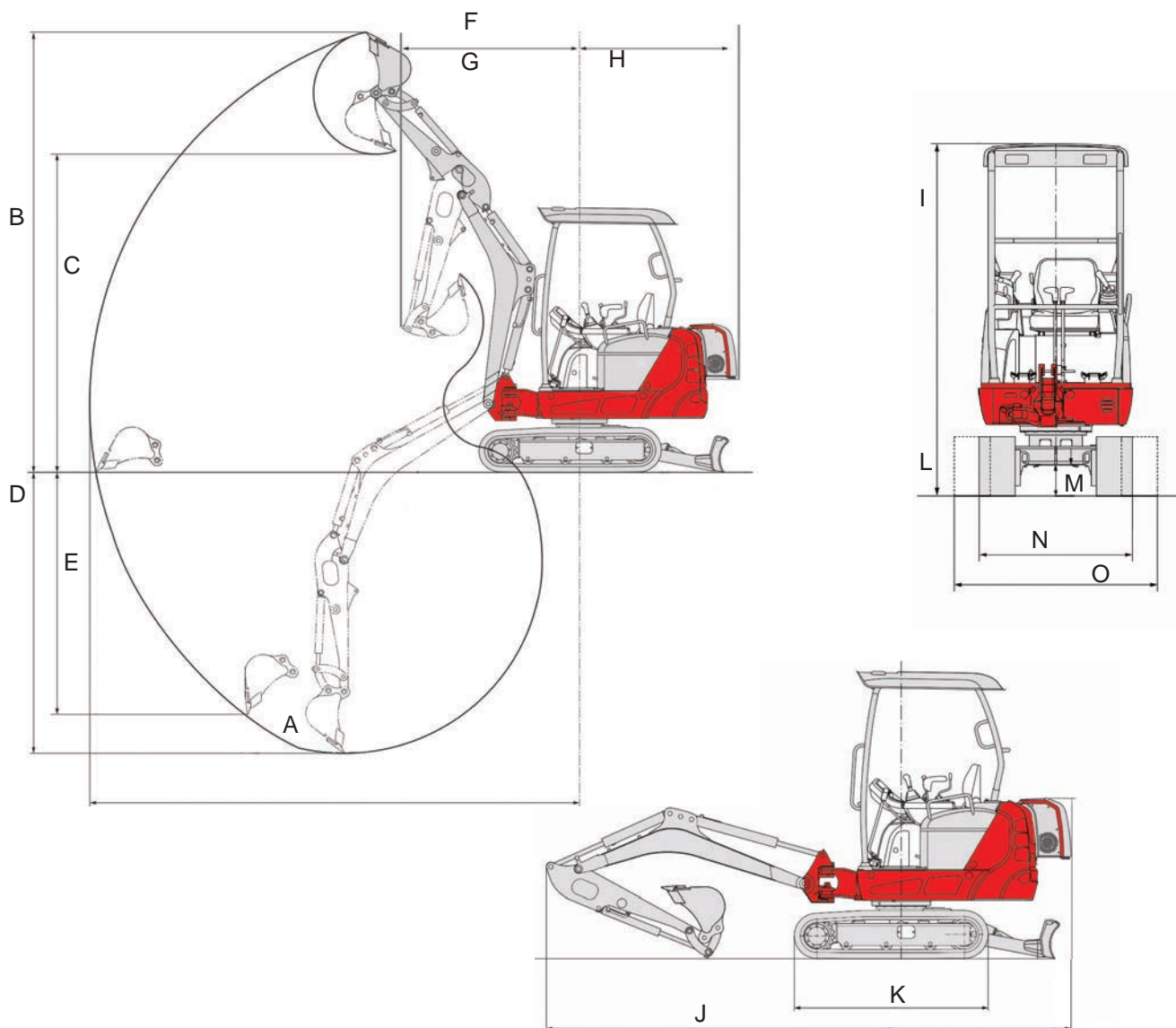

MACHINE DIMENSIONS

A	Maximum Reach	13 ft 5.0 in	(4,090 mm)
B	Maximum Dig Height	12 ft 3.2 in	(3,740 mm)
C	Maximum Dump Height	8 ft 10.5 in	(2,705 mm)
D	Maximum Dig Depth	7 ft 10.0 in	(2,390 mm)
E	Maximum Vertical Dig Depth	6 ft 9.1 in	(2,060 mm)
F	Front Swing Radius	4 ft 10.3 in	(1,480 mm)
G	Front Swing Radius (Offset)	3 ft 9.4 in	(1,155 mm)
H	Tail Swing Radius	4 ft 4.6 in	(1,335 mm)
I	Transport Height	7 ft 4.8 in	(2,255 mm)
J	Transport Length	13 ft 6.8 in	(4,135 mm)
K	Undercarriage Length	4 ft 11.9 in	(1,520 mm)
L	Track Width	9.0 in	(230 mm)
M	Ground Clearance	8.1 in	(205 mm)
N	Track Width Retracted	38.6 in	(980 mm)
O	Track Width Extended	51.2 in	(1,300 mm)



Power Supply and Tether



On / Off Switch



Shared Controls

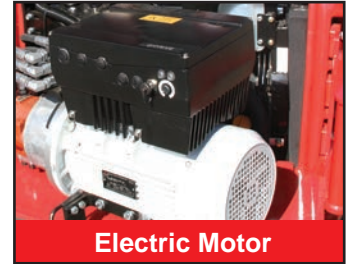

Electric Motor

The TB216H is a dual powered machine that includes a diesel engine and electric motor that allows for working indoors and outdoors. Both the engine and motor comes equipped with its own set of hydraulic pumps to power the machines hydraulics.

The diesel engine can be used to load, unload, and power the machine to an enclosed job-site where it can then be plugged into a 400-480v, three phase power source for 100% emission free operation.

For greater versatility and convenience the TB216H utilizes the same controls for all machine functions, including the keyed ignition and throttle control. Should the machine be connected to electric power while running the diesel engine, the diesel engine will shut off and the machine will begin to run off electric power once key is cycled. The TB216H is rugged, dependable, and extremely versatile. It provides outstanding performance and greater versatility with its dual power options.



2 YEAR
2,000 HOUR
FULL MACHINE
WARRANTY

Easy Maintenance and Service Access