

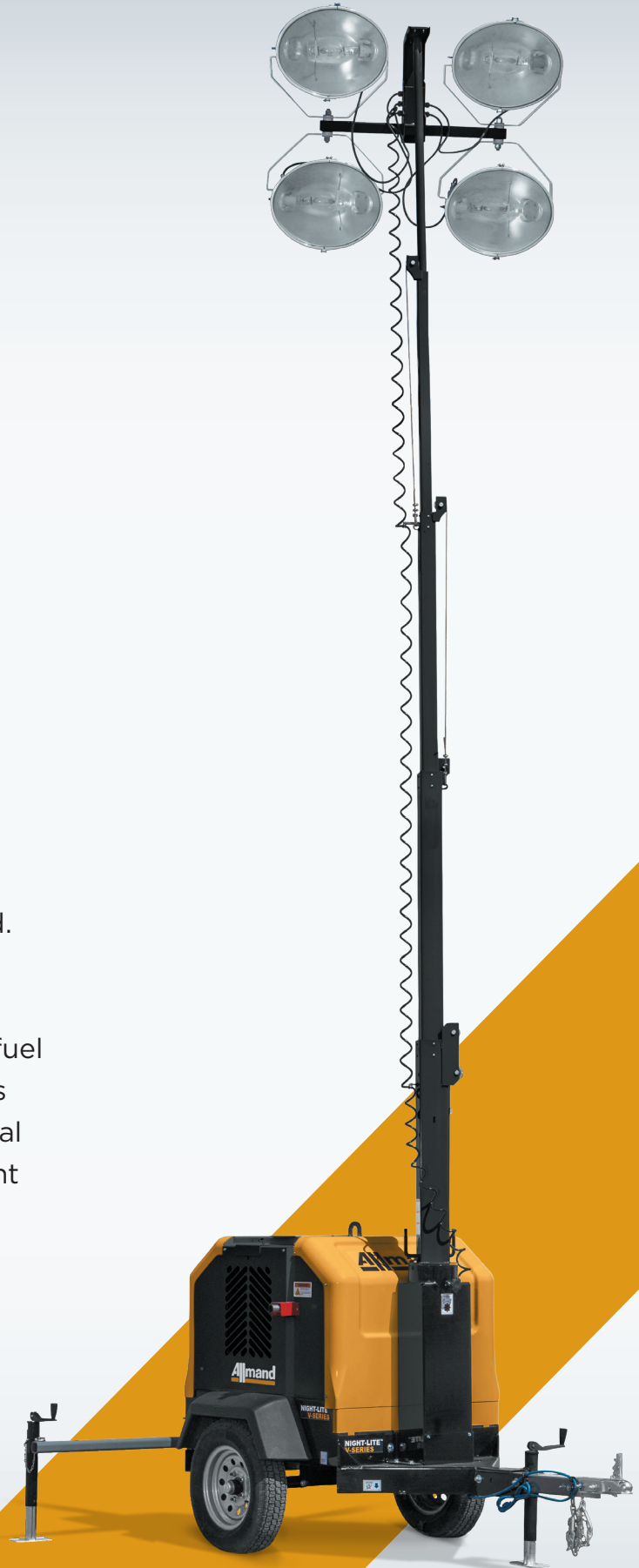

NIGHT-LITE™

V-SERIES®

An ROI-driven solution, the **Night-Lite™ V-Series®** is built with the efficiency, durability and performance you demand. This unit will run from 73 to 155 hours between refueling with metal halide or LED respectively, and has a convenient fuel fill neck for quick refueling. Plus, it offers 542,000 total lumens from the four metal halide light fixtures and minimized freight costs by fitting up to twenty units on a flatbed trailer.



A SUBSIDIARY OF



BRIGGS & STRATTON CORPORATION

KEY FEATURES

Night-Lite™ V-Series®

Sequenced Light System (SLS™)

Automatically delays engine shutdown to turn off lights and prevent generator from shutting down while under load.

(4) Metal Halide Light Fixtures

(4) LED Light Fixtures (Optional)

Easy Fixture Adjustment

359° Fixture Rotation

55 mph Operating Wind Speed Rating

Guide Pads

Polyethylene self-lubricating

Structure

Five-section tubular steel design

Complete Tower Rotation

Lift Ring

All Steel Body Construction

Trailer Lighting

Stop, turn, tail lights / side marker lights / illuminated license plate bracket

Stabilizers

Three-point design, tongue jack, (2) retractable side outriggers at front of trailer

Remote Engine Oil and Coolant Drain

Easily accessible at rear of trailer

45 Gallon Polyethylene Fuel Tank

Tie Down Slots

Simple, Easily Accessible Controls

Max Height*

26 ft (7.9 m)

Height

Mast Lowered / Raised
8.5 ft (2.6 m) / 24.6 ft (7.5 m)

Width

Transport / Operating
53 in (1,346 mm) / 104.7 in (2,659 mm)

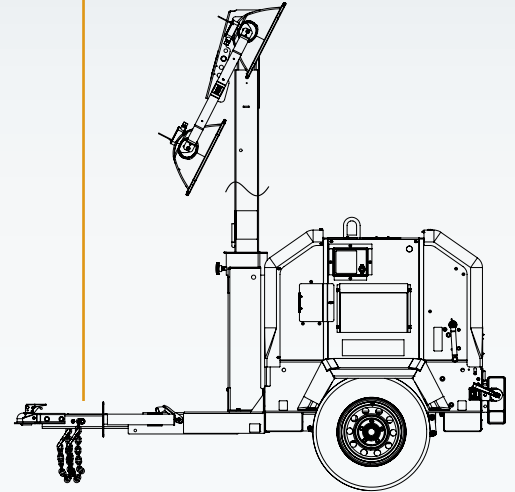

Length

Transport
78.8 in (2,002 mm)



Hour Meter

Actuation

Manual winch, standard

Exterior Fuel Fill

Fluid Containment System (FCS)

Holding up to 110% of all on-board fluids

Removable Tongue

Frame

Formed, welded steel frame

Axle

Tubular axle with elliptical leaf springs

Reversible Coupler

2" ball pinned tilt tongue

Forklift Pockets

Below the frame

Tires

ST175 / 80D13 load range 'C'

Model	NLV-ML3EC	NLV-K1005C	NLV-P11
Engine Brand / Model	Mitsubishi / L3E	Kubota / D1005	Perkins / 403D-11
Engine Prime Power (kW)**	6	7	8
Fuel Capacity gal (L)	45 (170.3)	45 (170.3)	45 (170)
Light Type - Metal Halide		(4) Metal Halide SHO-HD* fixture	
Metal Halide Wattage (per lamp)	1,250	1,250	1,250
Metal Halide Lumens (per lamp / total)	135,500 / 542,000	135,500 / 542,000	135,500 / 542,000
Operating Time (hrs)*** (Using four 1,250 W metal halide light fixtures)	75	72.6	75
Light Type - LED (Optional)		(4) Two LED, 5000°K color temperature	
LED Wattage (per lamp)	320	320	320
LED Lumens (per lamp / total)	38,500 / 154,000	38,500 / 154,000	38,500 / 154,000
Operating Time (hrs)*** (Using four 320 W LED light fixtures)	121.6	155.2	118.4
Features			
Outlets	Standard 20 A 120 VAC duplex GFCI / 30 A 240 VAC 4-Wire Twist Lock (NEMA L14-30R) / 30 A 120 VAC RV (NEMA TT-30R)		
Weights & Shipping			
Shipping Weight lbs (kg)	1,885 (855)		
Gross Vehicle Weight Rating (GVWR) lbs (kg)	2,200 (998)		
Shipping	18 units on a 48' flatbed trailer / 20 units on a 53' flatbed trailer		

LIGHT COVERAGE

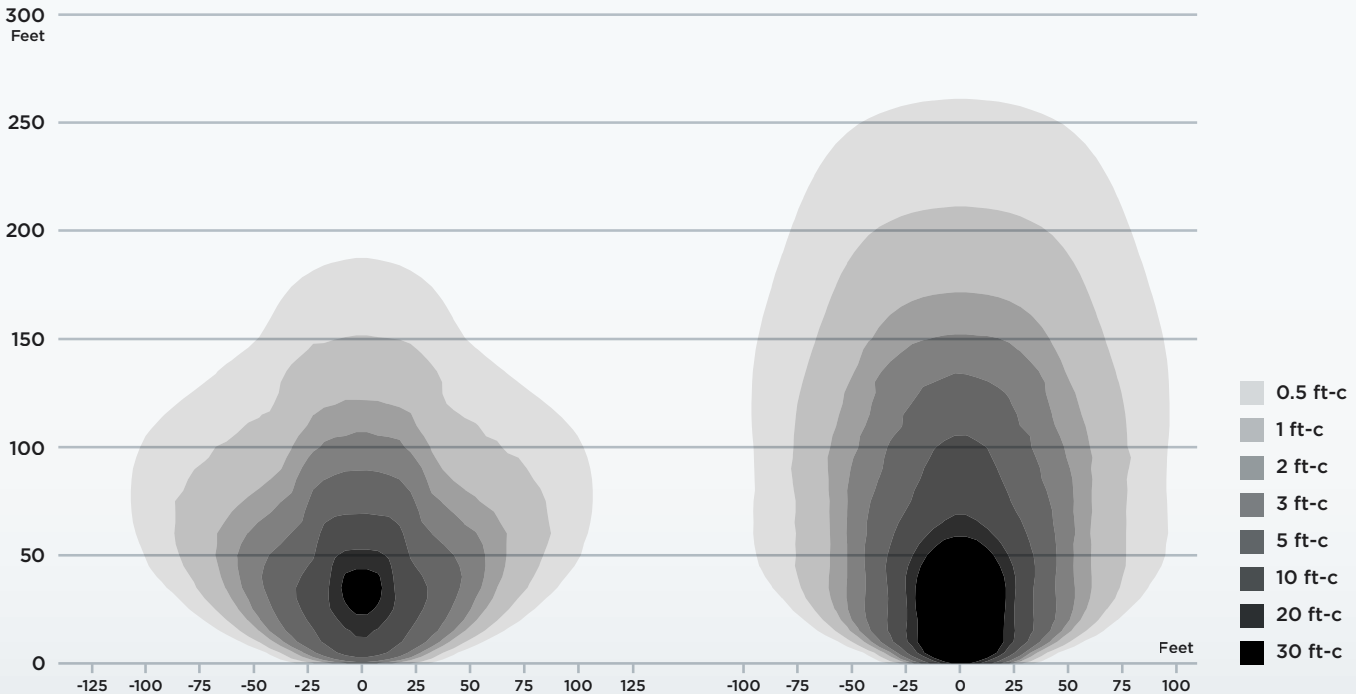

Night-Lite™ V-Series*
with 4 - 320 W Conssin LED Light Output
Area Lit to .5 Foot Candle (ft-c)
or Higher: 28,449 ft²

Night-Lite™ V-Series*
with 4 - 1,250 W Metal Halide Light Output
Area Lit to .5 Foot Candle (ft-c)
or Higher: 42,597 ft²

* Balloon light only included in raised dimension - balloon light is removed for transportation. ** Prime generator electrical output per Allmand® testing. *** Based on one hour run test full fuel tank consumption. Allmand® has a policy of continuous product improvement and reserves the right to modify its specifications at any time and without prior notice. See operator's manual or www.allmand.com website for complete warranty details.

OPTIONS

Night-Lite™ V-Series*



Arctic Package

- Heavy duty battery 775 CCA @ 0° F
- Block heater (120 VAC)

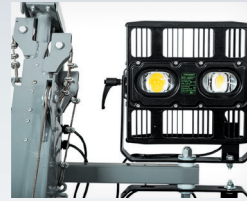

LED Package

- (4) LED light fixtures



LSC with E-Stop Package

(Not available with Mitsubishi Engine)

- LSC 2.1™ – Light Sequence Commander® automatically starts engine at sunset and shuts down engine at sunrise – programmable for user preferences.
- Emergency stop switch on exterior of machine

Marathon Alternator (Not available with Perkins Engine)

CSA (Metal Halide and LED)

Telematics Package (Customer supplied – consult factory)

Electric Winch Actuated Light Tower

Lockable Battery Disconnect

Reversible Coupler 2" ball with 3" pintle

Reversible Coupler 2" Bulldog® coupler with 3" pintle

Custom Paint

Fuel Level Gauge

Fluid Containment System (FCS)

Galvanized Tower



COMPROMISE NOTHING.

At Allmand, our sole focus is providing jobsite support equipment to help your customers get the job done. Whenever they need it. Wherever they are. And whatever it takes. What's more, our genuine commitment to you — the highest standard of service and lowest total cost of ownership — is simply unmatched. Choose the equipment that comes with complete confidence that jobsite productivity won't go dark at 2 a.m. **Allmand. Above All.**