



For: Wheel Loaders

Type: Forks

Applications: Pipeline Recycling General Utility Work

Features At-A-Glance

- Carriage widths from 60" - 106".
- Tine lengths from 48" - 96".
- Heavy duty oversized tine shaft provides maximum strength and durability.
- True forged steel tines.
- Manually adjustable tines. Swing and non-swing options available.
- Available in pin-on and various coupler hook-ups (Volvo®, JRB®, etc.).

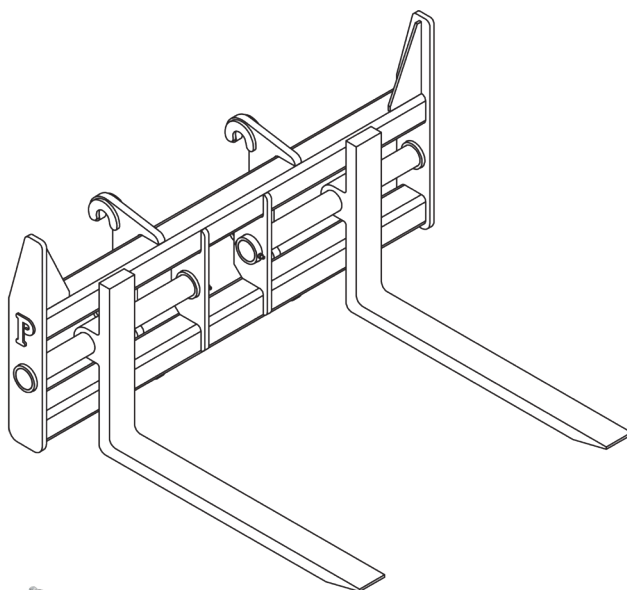
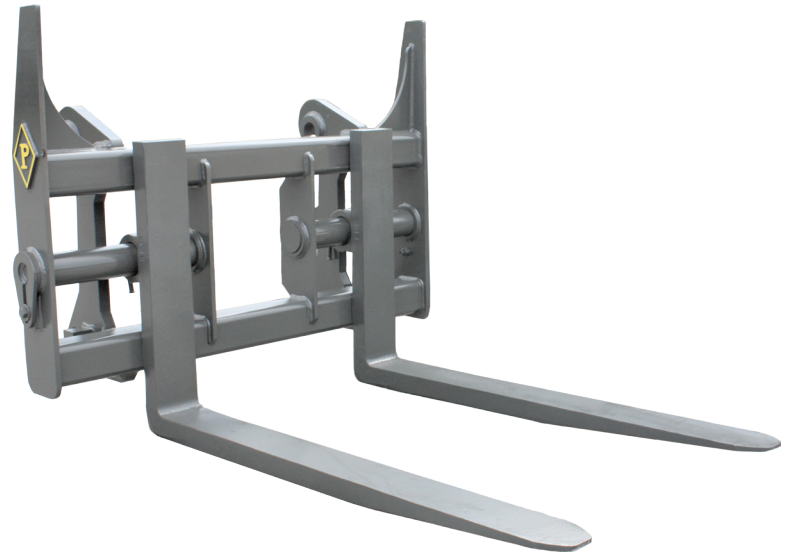

Loader Class	Carriage Width	Tine Length	Carriage Height at end plate	Shaft Length	Approx. Weight *
L-100	60"	54"	44"	FULL	900 lbs
L-200	80"	48" - 60"	50"	35" / 45"	1,100 lbs
L-300	80" - 96"	48" - 72"	50"	35" / 45"	1,300 lbs
L-500	80" - 96"	48" - 72"	50"	35" / 45"	1,450 lbs
L-600	96"	60" - 72"	50"	35" / 45"	1,600 lbs
L-700	96"	72" - 96"	51"	35" / 45"	1,700 lbs
L-800	96"	72" - 96"	60"	35" / 45"	1,850 lbs
L-900	96" - 120"	96"	70"	varies	varies

* Weights vary depending upon carriage width and tine length.

